

Soil-less Agriculture at the Wat Pathumwanaram School:

Expansion through an Aeroponic Garden and Educational Material

Jon Anderson, Katelyn Comeau, Nicole D'Angelo, Jason Parker, Pipat Poovatanasedj, Valash Sirikate, Onpapat Wongratsameetham



Soil-less Agriculture at the Wat Pathumwanaram
School:
Expansion through an Aeroponic Garden and Educational
Materials

An Interactive Qualifying Project/Social Science Project Report
submitted to the Faculty of
WORCESTER POLYTECHNIC INSTITUTE and CHULALONGKORN UNIVERSITY
in partial fulfillment of the requirements for the
Degree of Bachelor of Science

by

Jon Anderson

Katelyn Comeau

Nicole D'Angelo

Jason Parker

Pipat Poovatanasedj

Valash Sirikate

Onpapat Wongratsameetham

Date: March 4th, 2011

Report Submitted to:

Professor Paul Davis

Professor Jennifer deWinter

Ajarn Rojrit Rojanathanes

This report represents the work of one or more WPI undergraduate students submitted to the faculty as evidence of completion of a degree requirement. WPI routinely publishes these reports on its web site without editorial or peer review.

Abstract

The Wat Pathumwanaram School in Bangkok is developing its comprehensive soil-less agriculture program, which includes the development of an aeroponic garden. Design and construction of the garden allows the school to diversify its soil-less techniques and strengthen its role as a demonstration school. Educational materials developed to incorporate active and visual teaching methods complement the school's agricultural curriculum, and have the potential to provide students with a more practical understanding of soil-less agriculture. This document describes the engineering design and curriculum development processes used to expand the school's program.

Acknowledgements

Our team would like to thank everyone who has assisted us throughout our project.

First, we would like to thank our project sponsor, the Wat Pathumwanaram School, for everything they have provided us with including a great place to work, guidance for the project, and financial support for the aeroponic garden.

We would also like to thank the Siam Kempinski Hotel for the generous donation that allowed us to construct the aeroponic garden.

We would like to thank Songyot Yongsiri, a Thai hydroponic expert responsible for the existing soil-less agriculture systems at Wat Pathumwanaram School, for his insight and donations that were crucial to building the aeroponic garden. We would like to thank Dr. Itthisuntorn Nuntagaj, an aeroponic expert at King Mongkut's Institute of Technology Ladkrabang, for his insight and suggestions on our garden design. We would like to thank Suntaree Gervais, a hydroponic expert who has operated hydroponic gardens in both Thailand and Hawaii, for her insight.

We would like to thank Worcester Polytechnic Institute and Chulalongkorn University for providing us this excellent opportunity to complete this project in Thailand.

Finally, we would like to thank our advisors, professor Paul Davis, professor Jennifer deWinter, and ajarn Rojrit Rojanathanes, for their advice and encouragement throughout this project. We would also like to thank professor Seth Tuler for his help in preparing us for this project before going to Thailand.

Executive Summary

At the Wat Pathumwanaram School in Bangkok, our project team designed and constructed an aeroponic garden and developed educational materials that employ active and visual learning to enhance the school's existing soil-less agriculture program. Soil-less agriculture is an innovative solution that addresses many of the challenges possessed by traditional soil-based agriculture. Recent developments in soil-less agriculture have made it possible to produce food in settings that are not feasible for soil-based agriculture. This technique is ideal for large cities because it does not require arable land. To encourage others to utilize innovations, like those in soil-less agriculture, the benefits must first be demonstrated effectively. Schools are ideal locations for demonstrating the benefits of such innovations because in addition to educating their students, they have the ability to reach out to the surrounding community.

Aeroponics is a modern technique of soil-less agriculture that delivers nutrients to plant roots through a mist. This cutting-edge technique is more efficient when compared to other soil-less methods, making better use of space, nutrients, and water. To strengthen its role as a demonstration school, the Wat Pathumwanaram School is looking to exhibit more diverse techniques in soil-less agriculture, specifically through aeroponics. Information from extensive background research and experts in soil-less agriculture allowed for the design and construction of an aeroponic garden capable of meeting the needs of the Wat Pathumwanaram School. The school needed a garden that can be easily maintained and operated, is cost effective, and is suitable for operation in Bangkok. Employing an engineering design process, our project team designed several aeroponic gardens to meet the needs of the school, selected the design that was most feasible, and constructed it on the school's rooftop. An engineering design process is proven effective in guiding a feasible solution to an open-ended problem. Since aeroponics is a new technique to the school, manuals accompany the garden detailing the construction, correct operation, and required maintenance. This provides the school with the necessary information to ensure functionality of the garden is maintained and the garden is a long-lasting fixture for the school.

In addition to designing and constructing the aeroponic garden, we developed material that heavily incorporate active and visual learning, valuable teaching methods that promote increased participation and motivation in students. Based on our gathered information, the Wat Pathumwanaram School currently relies on PowerPoint and traditional-based lectures to present information to the students in its agriculture classes. Using a curriculum development process, we determined that active and visual teaching methods have the potential to provide students at the school with a more practical understanding of soil-less agriculture and its benefits. Realizing this potential, our project team determined that an appropriate way to incorporate active and visual learning into the classroom is by uniting these teaching methods with the current teaching method used in the agriculture classes. Our team re-formatted and re-designed the PowerPoint presentations that are currently used by the agriculture teacher. The PowerPoint presentations are not only good visuals for students, but they have the potential to increase student interest. Our team also developed a PowerPoint based game that rewards teamwork and participation while reviewing important concepts in soil-less agriculture. Lastly, we created posters that are visuals for three different types of soil-less agricultural techniques demonstrated on the rooftop to help students visualize and understand the many types of soil-less agricultural techniques. Together, these components have the potential to provide students at the Wat Pathumwanaram School with a more practical understanding of soil-less agriculture.

Sustaining the aeroponic garden will require the assessment of its functionality and proper maintenance of the system. If this is successfully achieved, the school will possess a valuable tool that promotes the use of soil-less agriculture by demonstrating a different type of sustainable soil-less agriculture. Successfully incorporating the developed educational material into the current curriculum has the potential to provide students with a more practical understanding of soil-less agriculture. Assessing the developed material can determine the overall effects of the incorporated material on the students and, most importantly, an assessment allows for future recommendations to be made.

We have made contributions to assist the Wat Pathumwanaram School in developing its comprehensive agricultural program in order to demonstrate how soil-less agricultural techniques are sustainable and self-sufficient technologies.

Authorship

Section	Author(s)
Abstract	Jon Anderson, Katelyn Comeau, Nicole D'Angelo, Jason Parker
Executive Summary	Jon Anderson, Katelyn Comeau, Nicole D'Angelo, Jason Parker
1.0 Introduction	Jon Anderson, Katelyn Comeau, Nicole D'Angelo, Jason Parker
2.0 Background	Jon Anderson, Katelyn Comeau, Nicole D'Angelo, Jason Parker, Pipat Poovatanasedj, Valash Sirikate, Onpapat Wongratsameetham
3.0 Defining Interview and Design Processes	Jon Anderson, Katelyn Comeau, Nicole D'Angelo
4.0 Objective 1: Designing and Constructing an Aeroponic Garden for the Wat Pathumwanaram School	Katelyn Comeau, Nicole D'Angelo
5.0 Objective 2: Developing Educational Materials to Complement the Current Agricultural Curriculum at the Wat Pathumwanaram School	Katelyn Comeau, Nicole D'Angelo
6.0 Conclusions and Recommendations	Nicole D'Angelo
Appendix A: Semi-structured Interview Questions and Responses for Designing and Constructing the Aeroponic Garden	Refer to interviews
Appendix B: Semi-structured Interview Questions and Responses for Developing Educational Material	Refer to interviews
Appendix C: Organization Charts for All Gathered Information	Katelyn Comeau, Nicole D'Angelo
Appendix D: Aeroponic Garden Construction Manual	Jon Anderson, Pipat Poovatanasedj*
Appendix E: Aeroponic Garden Maintenance Manual	Jason Parker, Pipat Poovatanasedj*
Appendix F: Current Agricultural Curriculum at the Wat Pathumwanaram School	Pipat Poovatanasedj*, Onpapat Wongratsameetham*
Appendix G: Developed Educational Material	Katelyn Comeau, Valash Sirikate*, Onpapat Wongratsameetham*
Appendix H: Recognition Plaque for the Aeroponic Garden	Jon Anderson, Onpapat Wongratsameetham*

* Translated from Thai to English or visa versa

Table of Contents

ABSTRACT	I
ACKNOWLEDGEMENTS	II
EXECUTIVE SUMMARY	III
AUTHORSHIP	VI
LIST OF FIGURES	IX
LIST OF TABLES	X
1.0 INTRODUCTION	1
2.0 BACKGROUND: EDUCATING URBANIZED BANGKOK IN SOIL-LESS AGRICULTURE	3
2.1 URBANIZATION OF THAILAND	3
2.2 IMPORTANCE OF SECONDARY EDUCATION.....	6
2.2.1 <i>The Wat Pathumwanaram School and Soil-less Agriculture</i>	7
2.3 SOIL-LESS AGRICULTURE.....	8
2.3.1 <i>Hydroponics</i>	8
2.3.2 <i>Aeroponics</i>	10
2.4 CURRENT AGRICULTURAL CURRICULUM AT THE WAT PATHUMWANARAM SCHOOL	11
2.5 TEACHING METHODS	12
2.5.1 <i>Active Learning</i>	12
2.5.1.1 <i>Discovery Learning</i>	13
2.5.1.2 <i>Problem-based Learning</i>	14
2.5.1.3 <i>Collaborative Learning</i>	14
2.5.2 <i>Using Agriculture to Incorporate Active Learning</i>	15
2.5.3 <i>Visual Learning</i>	16
3.0 DEFINING INTERVIEW AND DESIGN PROCESSES	17
3.1 SEMI-STRUCTURED INTERVIEWS	17
3.2 ENGINEERING DESIGN PROCESS.....	19
3.3 CURRICULUM DEVELOPMENT PROCESS.....	19
4.0 OBJECTIVE 1: DESIGNING AND CONSTRUCTING AN AEROPONIC GARDEN FOR THE WAT PATHUMWANARAM SCHOOL	21
4.1 STEP 1: CLARIFYING THE PURPOSE OF THE AEROPONIC GARDEN	21
4.2 STEP 2: GATHERING PERTINENT INFORMATION TO CONSIDER ASPECTS OF AEROPONIC GARDENING	23
4.3 STEP 3: DEVELOPING DESIGN CRITERIA FOR THE AEROPONIC GARDEN.....	26
4.4 STEP 4: DEVELOPING POTENTIAL AEROPONIC GARDEN DESIGNS AND SELECTING A FEASIBLE SOLUTION	28
4.5 STEP 5: BUILDING THE AEROPONIC GARDEN, TRANSFERRING PLANTS, AND DEVELOPING CONSTRUCTION AND MAINTENANCE MANUALS	33
5.0 OBJECTIVE 2: DEVELOPING EDUCATIONAL MATERIAL TO COMPLEMENT THE CURRENT AGRICULTURAL CURRICULUM AT THE WAT PATHUMWANARAM SCHOOL	36
5.1 STEP 1: DETERMINING THE EDUCATIONAL GOALS FOR THE DEVELOPED MATERIAL	36
5.2 STEP 2: IDENTIFYING THE CONTENT TO BE COVERED BY THE DEVELOPED MATERIAL.....	38
5.3 STEP 3: DETERMINING APPROPRIATE TEACHING METHODS FOR THE DEVELOPED MATERIAL	40

5.4 STEP 4: DETERMINING AN APPROPRIATE APPROACH FOR ASSESSING THE DEVELOPED MATERIAL	43
5.5 STEP 5: DEVELOPING EDUCATIONAL MATERIAL THAT COMPLEMENTS THE CURRENT AGRICULTURAL CURRICULUM AT THE WAT PATHUMWANARAM SCHOOL	45
6.0 CONCLUSIONS AND RECOMMENDATIONS	50
6.1 OVERALL PROJECT CONCLUSIONS	50
6.2 ASSESSING AND SUSTAINING THE AEROPONIC GARDEN AT THE WAT PATHUMWANARAM SCHOOL	51
6.3 INCORPORATING AND ASSESSING THE DEVELOPED EDUCATIONAL MATERIAL	53
REFERENCES	58
APPENDIX A: SEMI-STRUCTURED INTERVIEW QUESTIONS AND RESPONSES FOR DESIGNING AND CONSTRUCTING THE AEROPONIC GARDEN.....	63
APPENDIX B: SEMI-STRUCTURED INTERVIEW QUESTIONS AND RESPONSES FOR DEVELOPING EDUCATIONAL MATERIAL	71
APPENDIX C: ORGANIZATION CHARTS FOR ALL GATHERED INFORMATION ..	76
APPENDIX D: AEROPONIC GARDEN CONSTRUCTION MANUAL.....	78
APPENDIX E: AEROPONIC GARDEN MAINTENANCE MANUAL	117
APPENDIX F: CURRENT AGRICULTURAL CURRICULUM AT THE WAT PATHUMWANARAM SCHOOL	142
APPENDIX G: DEVELOPED EDUCATIONAL MATERIAL	148
APPENDIX H: RECOGNITION PLAQUE FOR THE AEROPONIC GARDEN	156

List of Figures

Figure 2.1: Exponential Growth of Thailand’s Economy (1951-1991).....	3
Figure 2.2: Land Use Map of Northern Bangkok Comparing 1952 to 1998.....	5
Figure 2.3: The Hydroponic Technique.....	9
Figure 2.4: The Aeroponic Technique.....	11
Figure 4.1: Aeroponic Garden Design 1.....	28
Figure 4.2: Aeroponic Garden Design 2.....	30
Figure 4.3: Aeroponic Garden Design 3.....	31
Figure 4.4: Model of Selected Aeroponic Garden Design.....	33
Figure 4.5: Completed Aeroponic Garden.....	34
Figure 5.1: Example Slide from Soil-less Agriculture PowerPoint Presentation.....	46
Figure 5.2: Main Game Board for Soil-less “Jeopardy” Game.....	48
Figure 5.3: Soil-less Agriculture Poster.....	49

List of Tables

Table 2.1: Per Capita GDP compared to Number of Years Completed in School	6
Table 2.2: Advantages and Disadvantages of Hydroponic Soil-less Agriculture.....	10
Table 4.1: Rooftop Site Evaluation at the Wat Pathumwanaram School	23
Table 4.2: Advantages and Disadvantages for Aeroponic Garden Design 1	29
Table 4.3: Advantages and Disadvantages for Aeroponic Garden Design 2.....	30
Table 4.4: Advantages and Disadvantages for Aeroponic Garden Design 3.....	32
Table 5.1: Educational Goals and Related Objectives for Developed Educational Material	37
Table 5.2: Educational Goals and Questions to Consider to Determine if Goals were Achieved	44

1.0 Introduction

Over the past 60 years, Thailand has experienced a rapid economic shift from an agricultural economy to one that is heavily focused on industry and service. As the industrial and commercial job markets have emerged, areas such as Bangkok have faced significant urbanization.

Additionally, the metropolitan land surrounding the city has transformed from arable land to commercially developed land, in order to accommodate the population increase and support new industries. The change in land use has presented the challenge of sustaining food production in Bangkok, which is crucial for the self-sufficiency of the city. Bangkok must educate its residents about alternative solutions to address these challenges of food sustainability and self-sufficiency.

As a royal demonstration school, the Wat Pathumwanaram School in Bangkok has been charged with providing its students and the surrounding community with a quality understanding of how to utilize technology to promote sustainable practices and self-sufficiency. Soil-less agriculture is one modern technology used at the Wat Pathumwanaram School that has the potential to be an alternative solution for food production in Bangkok. The school currently incorporates hydroponics, a specific technique in soil-less agriculture, into its comprehensive agricultural program as a way to demonstrate a sustainable and self-sufficient technology.

The Wat Pathumwanaram School realizes that it cannot solve the food sustainability problem in Bangkok alone; however, as a demonstration school it has the tools to disseminate knowledge about soil-less agriculture to its students and the surrounding community. The school understands that there is room for further growth and development within its agricultural program. It seeks assistance in diversifying and better demonstrating techniques in soil-less agriculture to its audience. It also hopes to provide its students with a practical understanding of the benefits of sustainable soil-less agriculture.

The goal of this project is to assist the Wat Pathumwanaram School in developing its comprehensive agricultural program in order to demonstrate how soil-less agricultural techniques are sustainable and self-sufficient technologies. To accomplish this goal, two objectives were established:

1. Design and build an aeroponic garden to demonstrate a different type of soil-less agricultural practice to students at the Wat Pathumwanaram School and the surrounding community.
2. Develop educational material that complements the current agricultural curriculum at the Wat Pathumwanaram School and has the potential to provide students with a more practical understanding of soil-less agriculture.

By achieving these two project objectives, we hope to make contributions in assisting the Wat Pathumwanaram School in developing its comprehensive agricultural program. Such contributions have the potential to better demonstrate how soil-less agricultural techniques are sustainable and self-sufficient technologies.

This report begins by describing the background knowledge important for understanding the context of our project. It moves into the methods we used to gather and analyze data necessary for designing and constructing the aeroponic garden, as well as developing educational material. The report concludes by offering the next steps that can be taken by the Wat Pathumwanaram School to further strengthen its soil-less agricultural program.

2.0 Background: Educating Urbanized Bangkok in Soil-less Agriculture

The information in this chapter describes how the urbanization of Bangkok has resulted in challenges with sustaining food production within the city and the use of self-sufficient practices by the residents of Bangkok. This chapter explains the importance of educating Bangkok residents on alternative solutions that are sustainable and self-sufficient to address these challenges. Next we outline the mission of the Wat Pathumwanaram School in Bangkok and how the school strives to educate its students on the benefits of soil-less agriculture as a sustainable, self-sufficient practice. From here, we present a working knowledge of soil-less agriculture, in-particular the hydroponic and aeroponic techniques. The remaining portion of this chapter covers educational methods appropriate for increasing student participation.

2.1 Urbanization of Thailand

The economy of Thailand has drastically changed over the past 60 years. For nearly a century leading up to World War II, little economic growth occurred in Thailand, but in the several decades following the War, the strength of the economy grew exponentially. Figure 2.1 from the book, “The Thai Economy in Transition,” by Warr (1993) shows the exponential growth of Thailand’s economy by comparing the per capita gross domestic product (GDP), normalized at 1972 prices, for the years between 1951 and 1991.

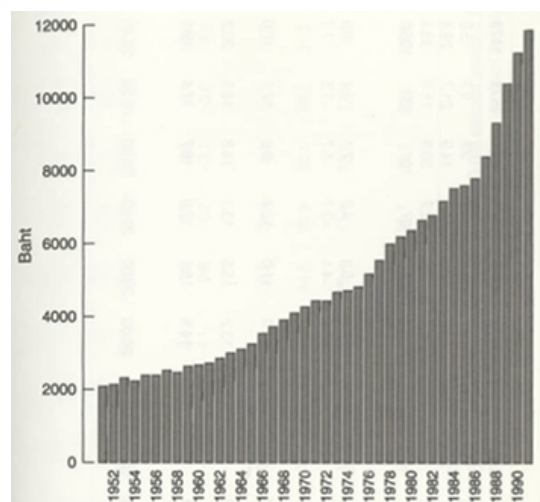

Figure 2.1: Exponential Growth of Thailand’s Economy (1951-1991)

This growth was due in part to the change in the source of Thailand's GDP. In his book Warr explains that, historically, the nation's financial stability depended on agriculture and exportation of rice and other crops. The CIA World Factbook (2011) states that today nearly 90% of the country's GDP comes from industry and service, and just 10% is gained through agricultural means. According Dr. Haapala (2002), an expert in urban studies, Thailand is now a major exporter of manufactured goods instead of food products. Thailand's economy has become more industrial leading to a shift away from an agricultural economy.

Along with these economic changes, the surrounding areas to Bangkok have become urbanized as the city has grown outwards. Meanwhile, many people have migrated from rural locations into the city, typically in search of jobs. Haapala further states that it is estimated that in the past 20 years, the entire rural population of Thailand has increased by just 0.3 million people, while the urban population has grown by 15 million people. The CIA World Factbook explains that today, more than a third of all Thai people live in cities. The U.S. Department of State (2010) and Haapala explain that Bangkok is a prime example of urbanization, as the population of this city has expanded by more than 10 million residents since the Vietnam War. According to FAO (Food and Agriculture Organization of the United Nations) representative Matuschke (2009), population studies show that 40% of this growth is due to migration by rural residents. The high growth rates and rapid influx of people into Bangkok demonstrates that the city has become urbanized. This urbanization is another change that the population, specifically in Bangkok, must face along with the challenges that it brings.

The increasing population and urban sprawl in Bangkok has resulted in a substantial decrease in the amount of arable agricultural land in and around the city. According to Tonmanee and Kuneepong (2004), officials from the Land Development Department in Thailand, much of the agricultural land in Bangkok has been converted into industrial, residential, and commercial uses to accommodate the changing economy and urbanization. Figure 2.2 from Hara, Takeuchi, and Okubo (2005) at the University of Tokyo, shows a land-use map of northern Bangkok comparing between the years 1952 and 1998.

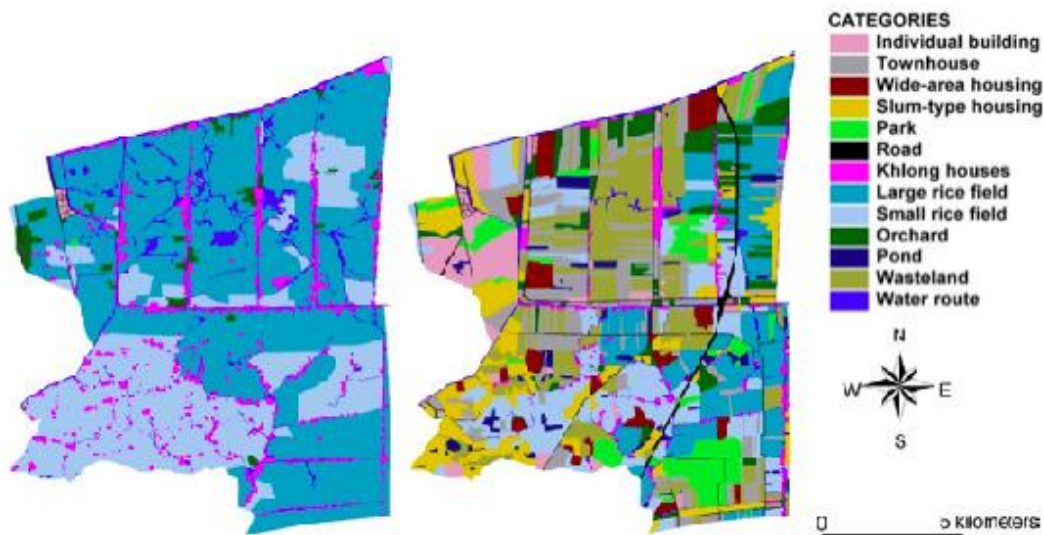

Figure 2.2: Land Use Map of Northern Bangkok Comparing 1952 to 1998

Hara et al explains the map shown in Figure 2.2 and that it demonstrates that much of the arable land in 1952 is now being used for residential purposes, wasteland, and commercial development. Land development in Bangkok is expanding outwards from the city as well. In many cases, housing developments have been built in the middle of rice paddy fields as the demand for housing increases. The decrease in agricultural land presents difficulties because the land is necessary in order for Bangkok to become self-sufficient and capable of producing its own food for the city's population.

The combination of changes in land usage, population growth, and economic shifts away from agriculture have led to the challenge of being able to meet high demands for food in the future, particularly in Bangkok. Urbanization and the changes in land use affect the ability of people to obtain locally grown, sufficient, and nutritious food. Jongkroy (2009), from the Department of Geography at Kasetsart University, explains that today agricultural areas in and around Bangkok contribute only 3% of the GRP (Gross Regional Product) for the 10 million people in Bangkok. In a 2010 case study, Chung, Ritoper, Takemoto concluded the urban poor population in Bangkok especially faces problems of access to food and that Thailand's agricultural economy is now heavily export based. Suteethorn (2009) states in her paper, "Urban Agriculture: Ecological

Functions for Urban Landscape” that the urban farms that once produced food for Bangkok residents have started to disappear. The city food supply is decreasing and without this urban agricultural land, the challenge of sustaining the food supply for the millions of citizens of the Bangkok Metropolitan is apparent.

Bangkok must educate its residents on alternative solutions that are sustainable and self-sufficient to alleviate the challenges. Schools are ideal locations for spreading knowledge about new technologies and techniques that are sustainable and self-sufficient.

2.2 Importance of Secondary Education

National economies tend to grow at a faster rate when more members of society receive a secondary education (seventh grade to twelfth grade) or higher. The World Bank Group (2009) states that achieving a higher level of education not only improves the economic well-being of individuals, but also an entire country, and is the key to economic growth. In addition, secondary education, allows the opportunity for a country to produce a well-trained and capable workforce, and overall well-rounded members of society. The World Bank Group (2010) explains that a nation with a workforce that is well-trained and capable is likely to experience economic as well as social growth and development. Information from Bollag (2003), an author for the Chronicle of Higher Education, was compiled for Table 2.1, showing per capita GDP growth rates for Chile, Malaysia, and Thailand in relation to the number of years spent in school.

Table 2.1: Per Capita GDP compared to Number of Years Completed in School

	Year: 1960		Year: 2000	
	Time Spent in School (# Years)	Per capita GDP (USD)	Time Spent in School (# Years)	Per capita GDP (USD)
Chile	6.19	4,000	10	7,000
Malaysia	3.22	2,000	9.31	6,000
Thailand	2.6	1,500	7.51	4,000

These specific examples show the correlation between more years spent in school resulting in a higher per capita GDP. For example Table 2.1 shows that in Thailand the per capita GDP more than doubled with approximately a five year increase in time spent in school. These statistics show the impact that receiving an education can have on a country's overall economy. The World Bank Group (2010) stresses that achieving a higher level of education is necessary in creating more opportunities for individuals, as well as countries with emerging economies. The knowledge and skills provided by a secondary education can lead towards economic growth and sustainability, and are directly related to the goals of the Wat Pathumwanaram School in Bangkok, Thailand.

2.2.1 The Wat Pathumwanaram School and Soil-less Agriculture

The Wat Pathumwanaram School hopes to provide its students with the knowledge and skills necessary to be an active and contributing member of Thai society. Under the patronage of Her Royal Highness Princess Maha Chakri Sirindhorn, the Wat Pathumwanaram School is a primary and lower secondary school for children at the levels of kindergarten through ninth grade. Although the school is located in the center of Bangkok's commercial district, the students at the school are typically from low-income households. In addition to its role as a primary and lower secondary school, the Wat Pathumwanaram School is also a royal demonstration school. As a royal demonstration school, it has been charged with providing its students and the surrounding community with a practical understanding of how to utilize technology to promote sustainable economic practices and self-sufficiency. The school's mission is to strive to provide a quality education through the use of innovative technologies to its students, and to demonstrate sustainable economic practices to its students and the surrounding community. It currently promotes a sustainable economic and soil-less agricultural practice with its developed hydroponic garden. The current hydroponic garden is primarily used to provide fresh produce for the school's lunch program. The Wat Pathumwanaram School also works to incorporate hydroponics into its agricultural curriculum as a way to demonstrate a sustainable, soil-less agricultural technology to its students and the surrounding community.

The Wat Pathumwanaram School is committed to its mission and its role as a demonstration school. It is hoping to work towards developing its comprehensive agricultural program in order to further demonstrate how soil-less agricultural techniques are sustainable and self-sufficient technologies to its students and the surrounding community. The school wishes to expose its students and the surrounding community to other developing soil-less agricultural practices with the design and construction of a new demonstration garden using a different soil-less agricultural technique, aeroponics. The school also hopes to make improvements to its current agricultural curriculum with the development of educational materials that will provide students with a more practical understanding of hydroponics and soil-less agriculture, as well as complement the current curriculum. In achieving these goals, the Wat Pathumwanaram School will be developing its comprehensive agricultural program while working towards its mission and role as a demonstration school.

2.3 Soil-less Agriculture

Soil-less agriculture is an innovative way of growing plants and other produce on both a household and commercial scale, without the use of a soil medium. In replacement of the soil is a nutrient solution that provides plants with the necessary elements for survival. According to Dr. Itthisuntorn Nuntagij (2011), professor of agriculture at KMITL (King Mongkut's Institute of Technology Ladkrabang), soil-less agriculture includes three components: hydroponics, in which plant roots are submerged in nutrient solution, aeroponics, when plant roots are sprayed with nutrient solution, and substrate culture, where plant roots are supported by a solid medium but given nutrients through a drip nutrient solution. For the purpose of our project, we elaborate on both the hydroponic and aeroponic techniques. We present the advantages and disadvantages of each, providing a means for comparison between the two soil-less techniques.

2.3.1 Hydroponics

Hydroponics is a soil-less agricultural technique where the soil is replaced by an aqueous nutrient solution, making it a viable option for situations where traditional agriculture techniques are impractical. Figure 2.3 is an image of a typical hydroponic garden.



Figure 2.3: The Hydroponic Technique

A rooftop in an urban area, such as the one at Wat Pathumwanaram School, is a good example of an environment where soil-less agriculture, and therefore hydroponics, is appropriate and traditional soil-based agriculture is impractical. The advantages hydroponics has over traditional soil-based agriculture justify why it is a suitable technique for Wat Pathumwanaram School to teach their students. For example, hydroponics does not require arable land, allows for the possibility of a year-round harvest, and has a faster growth cycle. Information from the following soil-less agriculture experts: Hopkins and Hüner (2004), Jones (1997), and Resh (1995) were combined to create Table 2.2, showing the advantages and disadvantages of hydroponics as a soil-less agricultural technique.

Table 2.2: Advantages and Disadvantages of Hydroponic Soil-less Agriculture

Advantages	Disadvantages
<ul style="list-style-type: none"> · Does not require arable land · Better utilization of space · Year-round productivity · Faster growth cycle · Increased yield · Less maintenance labor required · Less need for pesticides 	<ul style="list-style-type: none"> · Large initial investment · Reliance on electricity · Problems spread more rapidly · Specific maintenance and operation knowledge required

The advantages and disadvantages presented in Table 2.2 can be used as considerations before starting a hydroponic system. Despite there being some disadvantages, it is important to keep in mind that there are also many advantages. Hydroponics is an ideal form of sustainable agriculture for cities such as Bangkok. If the resources for starting and maintaining a hydroponic garden are available, hydroponics can be successful in overcoming obstacles that can be encountered with traditional agriculture.

2.3.2 Aeroponics

The Wat Pathumwanaram School expressed interest in adding aeroponics to its soil-less agricultural program because it is appropriate for an urban setting and an efficient soil-less technique. According to the National University of Singapore (2000), “Aeroponics appears to be the perfect solution for urban agriculture in land and water scare countries.” Designing aeroponic gardens to be vertical rather than horizontal allows it to be used in areas with little available space, such as rooftops. The technique has been shown to use just 10% of the water and 60% of the fertilizer that is necessary for horizontal hydroponic beds, increasing the productivity of the system. Because the roots are exposed to a large amount of oxygen, the plants also develop very quickly and the harvest cycle can be shortened from approximately 60 to 30 days. Aeroponics is also a good technique if year-round harvest is desired and arable land is scarce. Figure 2.4 is an

image from Growshop.com (2010) of an aeroponic system, where the nutrient solution is being sprayed onto the plant roots from below.

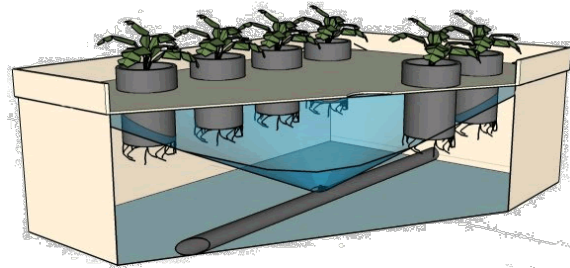

Figure 2.4: The Aeroponic Technique

Although aeroponics has many benefits, implementing this system requires knowledge of the potential drawbacks. According to Munson’s report, “An Evolutionary Deployable Greenhouse for Mars,” (2001), aeroponic beds often require a large amount of care to prevent the nozzles from clogging, the power source from going out, and the exposure to high temperatures. These conditions would be detrimental to the health of the plants. To prevent the nozzles from clogging, filters can be installed to remove impurities from the nutrient solution. The internal temperature of an aeroponic system, or the root zone temperature, must stay relatively cool, as this is essential to maintaining healthy plants. According to He, Lee, and Dodd (2001), professors at the Nanyang Technological University, a temperate plant such as lettuce has an optimal growing temperature between 15 and 25 degrees Celsius but is capable of surviving at temperatures up to 40 degrees Celsius, but at a slower growing rate. Understanding the limitations to aeroponics is important to successfully implementing and operating the system.

2.4 Current Agricultural Curriculum at the Wat Pathumwanaram School

The Wat Pathumwanaram School provides an agriculture class as a requirement for students in seventh to ninth grade. Due to a large class size, the agriculture teacher Ajarn Lalita primarily uses lectures and power point presentations as a teaching media in her class. Students have the opportunity to study about soil-less agricultural practices, specifically hydroponics, as well as traditional farming. The Wat Pathumwanaram School has realized that its students do not have a practical understanding of hydroponics and soil-less agriculture, and wishes to meet this need by

focusing its agricultural curriculum. The Wat Pathumwanaram School's goal is to provide its students with a more practical understanding of hydroponics and soil-less agriculture. In order to give students a better understanding of soil-less agricultural techniques as sustainable and self-sufficient practices, the school can look at ways to even further improve their current agricultural curriculum.

2.5 Teaching Methods

There is evidence that students who actively participate in the classroom learn better in comparison to rote methods. Active learning can engage students, increase understanding, promote long-lived retention, increase problem-solving skills, and promote self-directed learning by actively engaging students in the learning process. Some variations of active teaching methods, all with their own advantages and disadvantages, are: discovery learning, problem based learning, and collaborative learning. It has been observed that active-learning methods are effective ways to teach agriculture to students. In addition, visual learning is a good teaching method that can lead to improvements in student learning and increased student interest.

2.5.1 Active Learning

Active learning, when students are active participants in their education, has been shown to be more effective at conceptual teaching than traditional rote methods of teaching. According to their article in the "American Educational Research Journal," Benware and Deci (1984) state that active learning has shown to better engage students, increase conceptual learning, and promote long-lived conceptual understanding. A 1984 study at the University of Rochester, in which half of the subjects were under the impression they would be teaching any learned material to others, showed that those students who thought they would be teaching others were more actively involved. These students were more motivated than those who were learning with no intent of teaching the material to others. In addition, the group who learned with an active motivation scored higher on a conceptual learning test and perceived themselves as being more actively engaged with the environment. Professors at the University of Maryland, Redish, Saul, Steinberg (1997), discuss a 1987 study that found that the introduction of active computer tutorials in a computer laboratory course led to improvements in students' ability to recognize and understand

concepts, when compared to students that were taught using traditional methods. This further shows that introducing active methods to students has the potential for producing a better understanding of concepts. In a 6,000 student survey of mechanics test data for an introductory physics course, Hake (1998), a physics professor at Indiana University, reported a greater increase in post-test scores for students that were taught with interactive engagement, when compared to students taught with traditional methods. This study suggests that active learning and interactive engagement can improve student learning and result in higher test scores. Professor at Linköping University, Bernhard (2010), found that students also retained a good conceptual understanding of material years after learning by active teaching methods. This is an example showing that active learning has the capability to provide a long-term conceptual understanding.

2.5.1.1 Discovery Learning

Discovery learning, a form of active learning in which the student discovers educational concepts as opposed to being directly taught, is not effective alone. According to professor of psychology Klahr and research associate Nigam (2004), it may be effective if students have prior knowledge on a subject matter or in a guided setting where students are led to the material that should be learned. In a 2004 study of third and fourth graders, discovery learning and direct instruction were compared. The study showed that those who learned from direct instruction did just as well as the students who learned from discovery methods. Based on the outcome of this study, there was no advantage of discovery learning over direct instruction. From Monen University, Tuovinen and Sweller (1999) conducted a study with two groups of students comparing discovery learning against teaching example problems. One group of students had some prior knowledge of the material while the others did not. They found that teaching example problems was more effective with the group who had no prior knowledge, and discovery learning was more effective with the students who had prior knowledge. Professor of psychology at the University of California Santa Barbara, Mayer (2004) explains that if students are given too much information they may fail to recognize the key concepts of what is being taught. Pure discovery learning may fail to promote the basic concepts relevant to the topic. Overall, there is a lack of evidence suggesting discovery learning as an effective teaching method in kindergarten through twelfth grade education.

2.5.1.2 Problem-based Learning

In some instances, problem-based learning, when students are required to solve problems, can increase problem-solving skills, critical thinking skills, self-directed learning skills, long-term retention of knowledge, student interest, and application of concepts in kindergarten through twelfth grade educational settings. According to an instructional design professor at the University of North Dakota, Hung (2002) explains that problem-based learning is a problem focused, student centered, self-directed, self-reflective method of teaching with the goal of enhancing learning. Hung reports that a study conducted on gifted high school students found that problem-based learning raised problem-solving skills. According to Hung, fourth and fifth grade students taught using problem-based learning showed an increase in critical thinking skills. Norman (1992), a professor at McMaster University, confirms that problem-based learning has been shown to increase retention of knowledge, lead to the better application of concepts, enhance student interest, and increase self-directed learning skills. In general, problem-based learning is supported as a method to enhance student learning.

2.5.1.3 Collaborative Learning

Collaborative learning is a form of active learning in which students share joint intellectual efforts. Professors from The Evergreen State College, Smith and MacGregor (1992) state that collaborative learning is a type of active learning that has been shown to result in an increase in student participation and enthusiasm. According to Terenzini, professor of education at Penn State University (2001), students who were taught using collaborative learning showed statistically significant improvements in learning. In another study by associate professor of political economy, Marangos (2000), students found collaborative problem-solving tutorials enjoyable and helpful to other subjects. A study by Doise (1975), Ph.D in social psychology, found that teamwork allowed for the easier completion of a task, which would have been difficult to complete alone. Collectively, these studies suggest that working together in groups, incorporating collaborative learning, can enhance a student's academic experience.

By integrating students with slightly different skill levels into working groups, collaborative learning can be more effective. According to professors of educational science at the University

of Groningen, Gijlers and De Jong (2005), a study investigated the effects of prior knowledge on knowledge development in collaborative learning. It was found that groups of students with varying skill levels were able to perform better academically. It was also found that if the gap in prior knowledge was too large, it was detrimental as one person would do all the work, having a negative impact on the rest of the group. These are important factors to take into consideration when developing educational material that incorporates collaborative and active learning.

2.5.2 Using Agriculture to Incorporate Active Learning

Short-term agricultural projects, when integrated into the classroom, can help foster science-process skill development. Urban Horticulturalist at the University of California Los Angeles, Mabie (1996), conducted an experiment testing the effects of experiential agriculturally based projects on the science-process skill development of fifth and sixth graders at an urban elementary school. Two methods, short-in class projects and long-term projects, were compared to traditional teaching methods. The study found that although both projects improved the students' science-process skills, short in-class projects were superior, as students stayed attentive and involved in the project throughout. This study shows that using short-term projects in a classroom setting can improve student learning in agriculture.

Experiments and hands-on activities are good tools within active learning to increase the impact of agriculture classes on students. A case study by Stajano (2004), President of the Uruguayan Society of Hydroponics, discusses the development of a hydroponics program at a kindergarten in Uruguay. The purpose of this hydroponics program was to teach many practical ideas to the students that could be used in further aspects of life. These concepts include:

- An understanding of the plant life cycle and the function of plants
- The process by which plants are produced and sold
- Knowledge of healthy eating habits
- Respect for nature

To teach the students about plants, not only were they taught how to water and feed the plants, they were also taught about the parts of plants and the germination process that occurs before

planting. These were taught using active methods as opposed to textbook learning. Each child was given the chance to look at plants under a magnifying glass, and each was given a specific plant to water and take care of. This allowed the children to gain a sense of ownership for the plants. The students also learned about the commercial side of farming by visiting a local grocery store and observing how the plants go from the garden to the shelf. This study found that many of the hydroponic practices used at this kindergarten were successful at teaching the young students. Many students showed an increased interest in plants, and some even wished to continue growing them in their homes. Additionally, 93% of the parents reported seeing motivation in their children after the program. This case study supports the idea of using hydroponics as a tool for active learning and how it can result in an increase in student engagement and interest.

2.5.3 Visual Learning

Visual learning is an appropriate component of teaching students about technologies. In his journal article for the Education Resources Information Center titled Visual Literacy and Learning in Science, Lowe (2000) discusses the importance of using pictures and graphics to explain technical ideas to students. Including visuals can be beneficial to teaching concepts that are difficult and complex. It helps improve understanding by presenting the material in a different way. He also explains that visual media plays a huge role in today's information based society thus educational materials should be visually attractive to gain the attention of their audience. Lowe concludes that visual learning is an essential part of educating students about science and technology. The technical nature of soil-less agriculture can make visual learning an appropriate method for teaching the technology at the Wat Pathumwanaram School.

3.0 Defining Interview and Design Processes

The goal of this project was to assist the Wat Pathumwanaram School in developing its comprehensive agricultural program in order to demonstrate how soil-less agricultural techniques are sustainable and self-sufficient technologies. To achieve this goal, the Wat Pathumwanaram School needed assistance in diversifying and better demonstrating techniques in soil-less agriculture. The Wat Pathumwanaram School also needed help in providing its students with a more practical understanding of sustainable soil-less agricultural techniques. To achieve this goal, we completed the following objectives:

1. Designed and built an aeroponic garden to demonstrate a different type of sustainable soil-less agricultural practice to the Wat Pathumwanaram School students and the surrounding community
2. Developed educational material that complemented the current agricultural curriculum at the Wat Pathumwanaram School that have the potential to provide students with a more practical understanding of soil-less agriculture.

We used semi-structured interviews to achieve both objectives. We used a basic engineering design process to achieve objective one, and a curriculum development process to achieve objective two.

3.1 Semi-structured Interviews

We found semi-structured interviews to be an appropriate means of gathering information for our project. According to “Qualitative Research Methods for the Social Sciences,” by Berg (2007), the interviewer decides the subject of the semi-structured interview and the overall goal of the interview is to understand the responder’s point of view and opinion. The interviewer can prepare questions prior to the interview, or they can emerge while in interview. The interviewer asks open-ended questions, allowing the interviewee to speak for themselves and express their opinion. Semi-structured interviews are not formal, and allow for a comfortable interview atmosphere. A comfortable interview atmosphere increases the chance of an interviewee expressing their true opinion on a matter. In the context of our project, semi-structured

interviews allowed us to gain knowledge that could not be found from background research and understand the expectations and opinions of the interviewees.

We conducted semi-structured interviews with the following constituents for the Wat Pathumwanaram School:

1. **Pataraporn Jirojyongse (Ajarn Pataraporn):** Administrator and our main contact and project liaison for the Wat Pathumwanaram School. Necessary to interview for understanding the specific goals of our project.
2. **Lalita Prasart (Ajarn Lalita):** The current agriculture teacher at Wat Pathumwanaram School and responsible for the soil-less agricultural program at the school.
3. **Ajarn Monlada Sukalarm:** Former teacher of biology at the Wat Pathumwanaram School. Familiar with the educational methods used at the school.

We conducted semi-structured interviews with the following hydroponic and aeroponic experts:

1. **Ajarn Suntaree Gervais:** Hydroponic expert who has practiced hydroponics in Thailand and Hawaii. Understands hydroponics in relation to Thailand.
2. **Ajarn Songyot Yongsiri (Ajarn Tun):** Hydroponic expert who works very closely with the Wat Pathumwanaram School. Heavily involved in the current soil-less agriculture program at the school.
3. **Dr. Itthisuntorn Nuntagij:** Professor at King Mongkut's Institute of Technology Ladkrabang (KMITL), aeroponic expert who has been heavily involved in aeroponic garden design and construction.

The application and use of semi-structured interviews to guide the design of the aeroponic garden is further discussed in Chapter 4.0. Chapter 5.0 discusses the use of semi-structured interviews to develop educational material for the Wat Pathumwanaram School.

3.2 Engineering Design Process

We used an engineering design process to achieve our first project objective. According to Khandani (2005), Ph.D in Mechanical Engineering from MIT, an engineering design process provides a structured set of steps for generating feasible solutions to a specific design problem. A design problem is typically defined loosely because there is not a correct solution, but rather several reasonable solutions. Professor of Education Research at Tufts University, Hynes (2010) claims that there are many specific engineering design processes and nearly all of them are a set of guiding steps between a specific problem and a feasible solution. In relation to our project, the Wat Pathumwanaram School has a problem that requires the generation of feasible solutions. The design of an aeroponic garden for the school was a priority as a solution to its problem. We met this requirement more efficiently and directly following an engineering design process. We discuss the application of an engineering design process used to achieve our first project objective in Chapter 4.0.

3.3 Curriculum Development Process

We used a curriculum development process to achieve our second project objective, a process also appropriate for designing materials complementary to a curriculum. It ensures that any newly developed material matches the needs of the school and the children, the method of teaching is appropriate, and the process can be improved upon by evaluating the end result. According to Kelting-Gibson (2005), professor of Curriculum and Instruction at Montana State University, when developing educational material, many educators follow a similar set of steps to ensure that the developed material is appropriate and effective. In general, this method consists of first identifying the educational goals by understanding the educational needs of the students. In her paper, "Curriculum Development," Professor Judith Howard at Elon University (2007) states that these goals identify what educators seek to teach their students and later allow for assessment of the effectiveness of the education. In her presentation, "Developing a Competency-based Curriculum," Joyce (2007) discusses the continuation of the process, stating that after educational goals have been identified, the content to be covered is chosen, followed by determining an appropriate method for presenting the material. Each method of teaching presents information in a different manner therefore some are better suited to educational goals. Of the

Center for Teaching Excellence at Virginia Commonwealth University, Polich and Goodell (2007) elaborate on the next step, determining a method/approach for assessing the success of the developed curricula. Tests, projects, assignments, self evaluations by the educator, and peer evaluations are examples of what can be used to gauge the students' retention of the developed material and whether or not the educational goals were achieved. To make future recommendations for improvement, the developed material should be assessed on its effects.

This approach is important and appropriate for developing educational material for the Wat Pathumwanaram School. The school desires educational material that meets a set of identified educational goals. Following a curriculum development process will ensure that the educational goals are met, recommendations for improvement can be made, and, ultimately, the developed educational material contributes to meeting the greater goal of this project. We discuss the application of a curriculum development process used to achieve our second project objective in Chapter 5.0.

Semi-structured interviews, the engineering design process, and the curriculum development process are appropriate methods that allow the identification of relevant information to guide us in achieving our two project objectives.

4.0 Objective 1: Designing and Constructing an Aeroponic Garden for the Wat Pathumwanaram School

In order to assist the Wat Pathumwanaram School in achieving its greater goal for this project, we designed and built an aeroponic garden to demonstrate a different type of sustainable soil-less agricultural practice to the Wat Pathumwanaram School students and the surrounding community. We followed an engineering design process appropriate for achieving this objective at the Wat Pathumwanaram School. The steps in the process were:

1. Clarifying the purpose of the aeroponic garden
2. Gathering pertinent information to consider in aspects of aeroponic garden
3. Developing design criteria for the aeroponic garden
4. Developing potential aeroponic garden designs and selecting a feasible solution
5. Building the aeroponic garden, transferring plants, and developing construction and maintenance manuals

Below we elaborate on the steps in this process and how each step helped in achieving this project objective.

4.1 Step 1: Clarifying the Purpose of the Aeroponic Garden

We clarified the purpose for the aeroponic garden at the Wat Pathumwanaram School using a semi-structured interview with our project liaison, Ajarn Pataraporn. From the interview, we determined why the Wat Pathumwanaram School wanted the garden to demonstrate specifically aeroponics, the audience for the garden, and the resources that would be available to us throughout the project. Our project liaison was an appropriate source for this information because she was in charge of managing extra-curricular activities and was the voice for the school regarding the aeroponic garden throughout this project. Interviewing our project liaison allowed us to tailor the design of the aeroponic garden to meet the needs of the Wat Pathumwanaram School. Refer to Appendix A.1 for the specific questions and responses gathered from this interview. From the interview, we determined:

- The mission of the Wat Pathumwanaram School is to demonstrate sustainable and self-sufficient practices to its students and the surrounding community.
- To create a demonstration aeroponic garden, the design should consider the audience, limited space, resources, and available funding.

The mission of the Wat Pathumwanaram School is to demonstrate sustainable and self-sufficient practices to its students and the surrounding community.

As a royal demonstration school, the Wat Pathumwanaram School models extra-curricular activities to its students, the surrounding community, and other primary and secondary schools. Our project liaison explained that like other aspects of the school, the aeroponic garden would be used as a demonstrational garden at the Wat Pathumwanaram School to expose students, the surrounding community, and other schools to the soil-less technique. In the interview with our project liaison, she made it clear that she wanted an aeroponic garden built to diversify the soil-less techniques at the Wat Pathumwanaram School, to increase its reputation as a demonstration school, and to work in achieving the school's mission statement by promoting sustainable and self-sufficient agricultural practices to its students and the surrounding community.

To create a demonstration aeroponic garden, the design should consider the audience, limited space, resources, and available funding.

As a demonstration garden, the design should keep in mind the audience. The garden should not be unreasonably sized or complicated so that the Wat Pathumwanaram School students and surrounding community members can grasp the way in which it works. The audience of the garden should understand that soil-less agriculture does not have to be a complicated sustainable practice. Our project liaison explained that a space had been reserved for the aeroponic garden on the rooftop of a new academic building at the school. She also explained that the school had only limited supplies for us from existing hydroponic systems. Our project liaison explained that the Wat Pathumwanaram School operates on a government-sponsored budget, so available funds for the aeroponic garden were scarce, and expressed concerns that the Wat Pathumwanaram School would not be able to support the construction of the garden.

4.2 Step 2: Gathering Pertinent Information to Consider Aspects of Aeroponic Gardening

Using a site evaluation of the rooftop and semi-structured interviews with hydroponic and aeroponic experts, we gathered pertinent information to consider in our aeroponic garden design.

A site evaluation of the rooftop allowed us to evaluate the specified space, identify environmental factors, and identify available resources to consider when designing the aeroponic garden specific to the Wat Pathumwanaram School. Table 4.1 below shows information gathered from the site evaluation.

Table 4.1: Rooftop Site Evaluation at the Wat Pathumwanaram School

Rooftop Component	Information Gathered
Size of room	6.62m x 9.00m
Wall height	1.54m
Doors	2 Doors, 1.8m wide, 1.95m high, 0.72m swing
Protection	Greenhouse roof, open walls with netting in place
Water source	2 faucets
Water drainage	5 drains
Electricity source	4 electrical outlets
Sun exposure	Moderate sun exposure between 10am and 5pm in winter
Objects on roof	2 vertical gardens, 2 hydroponic gardens, one cascading garden

The features most important to notice from the site evaluation are the appropriate availability of water and electricity on the rooftop. Without either of these factors, garden construction on the rooftop would not be practical. Another important factor to notice is that the rooftop has a

greenhouse roof and weather/bird prevention netting on its open walls to protect from some environmental factors such as intense sunlight, extreme rain, birds, and some insects.

We conducted semi-structured interviews with two hydroponic experts, Ajarn Suntaree Gervais and Ajarn Songyot Yongsiri (Ajarn Tun). From the interviews, we determined information about the benefits of soil-less agricultural techniques, ways to cut costs in soil-less garden design, and ways to sustain a soil-less garden after construction. We also conducted a semi-structured interview with an aeroponic expert, Dr. Itthisuntorn Nuntagij. From this interview, we determined advantages and disadvantages to aeroponics, aeroponic designs that are appropriate for Thailand and specifically Bangkok, required materials and sources for the materials in Bangkok, operational requirements for an aeroponic garden, and estimated costs of building an aeroponic garden that is appropriate for Bangkok. Refer to Appendix A.2 and Appendix A.3 for the questions and specific responses from each interview from the hydroponic experts and refer to Appendix A.4 for the questions and responses from the interview with the aeroponic expert. We considered information from all of these sources and identified aspects in design that we should consider for the aeroponic garden.

- A simple design is most appropriate for construction and for demonstration of the aeroponic technique.
- To ensure that the aeroponic garden is functional, it should be protected from extreme weather conditions.
- Maintaining the aeroponic garden is important for its success.

A simple design is most appropriate for construction and for demonstration of the aeroponic technique.

According to Dr. Itthisuntorn Nuntagij an A-frame garden design is the most basic of aeroponic designs. It is the simplest to build, easy to clean, and uses simpler plumbing than if the design were made from PVC piping. Ajarn Songyot Yongsiri (Ajarn Tun) explained that an A-frame design can be constructed from wood, which is cheaper than most other materials while still being a durable. An A-frame design was most appropriate for the Wat Pathumwanaram School

because it was cheaper in terms of construction costs, benefiting the school and its concerns about adequate funding for the garden. The simpler design would not only benefit our project group when it came time to construct the garden, but would benefit the garden's audience. The Wat Pathumwanaram School students and surrounding community members would not understand a complicated design and therefore the garden would not be an effective demonstration garden.

To ensure that the aeroponic garden is functional, it should be protected from extreme weather conditions.

An important component to the design should be consideration of the climate in Thailand. Thailand experiences extreme weather conditions. According to the Weather Channel (2011), during the rainy season (June-October), Bangkok can experience between 15-32 centimeters of rain per month. Throughout the summer months (March-May), April is the hottest month in Bangkok, with an average high temperature of 34°C. Excessive rain can be damaging to the equipment used in the aeroponic system as well as to the plant growth, while excessive heat can compromise the growth cycle of the plants. The rooftop evaluation revealed that the rooftop has two exposed sides with netting, and a green-house roof. These two factors will contribute to protecting the garden from the rain fall. According to Ajarn Tun an aeroponic system is not typically used in Thailand due to the extreme heat conditions. He informed us that the only commercial aeroponic garden in Thailand is in the more temperate Chiang Mai. He also explained that an aeroponic garden is susceptible to extreme heat because the plant roots are exposed to hot air, which impedes the growth of the roots. Ajarn Tun recommended that we consider ways to cool the system to the ideal temperature, as defined by He et al between 15 and 25 degrees Celsius. Dr. Itthisuntorn Nuntagij recommended we cool the system using a fan to push warm air out of the system. Ajarn Tun suggested that we insulate the garden from the hot floor using high-density foam. These extreme environmental factors in Thailand can be detrimental to success of an aeroponic garden if left unaddressed.

Maintaining the aeroponic garden is important for its success.

Many situations can naturally occur that can compromise the effectiveness of an aeroponic garden. Measures must be taken to prevent and combat these situations. According to Munson, research has shown that without regular maintenance, a common problem that occurs in aeroponic gardens is clogging of the nozzles. Munson also stresses the need for careful inspection of an aeroponic garden to prevent the failure of: the nozzles, the filter, the pump, and the power source. The failure of any of the components could be detrimental to plant growth. Our interview with Ajarn Suturee Gervais exposed that to prevent algae from growing and killing the plants, all soil-less gardens must be cleaned after each harvest cycle. She also warned us that the presence of bugs has the potential to ruin an entire harvest; therefore the underside of leaves must be carefully and frequently inspected. Members of the custodial staff, students, and teachers at the Wat Pathumwanaram School are going to be the main caretakers of the constructed garden. All must be aware of the proper and necessary steps required for a functioning garden. The garden must be maintained in order to be a demonstration garden and a strong example of a soil-less agricultural technique and sustainable practice.

4.3 Step 3: Developing Design Criteria for the Aeroponic Garden

The important design claims made above and other information gathered were organized into a comparison chart, shown in Appendix C.1. We looked for areas of similarity between the important design claims, and used these to develop three important design criteria for the aeroponic garden. A combination of the need of the Wat Pathumwanaram School, the rooftop evaluation, semi-structured interviews with two hydroponic experts and a semi-structured interview with an aeroponic expert led to the design criteria. The criteria are:

- The garden design should be easy to operate and maintain.
- The garden design should be cost effective.
- The garden design should be suitable for Bangkok.

The garden design should be easy to operate and maintain.

Our project liaison Ajarn Pataraporn explained that the primary audience of the aeroponic garden will be the Wat Pathumwanaram School students and surrounding community members. The garden design considered this, as a simpler design would be better understood by the audience. She also explained that students in an agriculture class at the Wat Pathumwanaram School will, at times, be responsible for maintaining the garden as part of the agricultural curriculum. With this in mind, the garden was designed so that there would not be any difficult maintenance requirements. An aeroponic garden that is easy to operate and maintain, especially for the students, will allow the Wat Pathumwanaram School to demonstrate, teach, and use this soil-less technique as a sustainable and self-sufficient practice, following its mission statement.

The garden design should be cost effective.

Ajarn Pataraporn explained that the Wat Pathumwanaram School had a limited budget and that she needed to make sure the garden would be an investment that would last long-term. An expensive design was unnecessary for the purpose of the aeroponic garden. As a demonstration garden, an expensive design is not desirable because it would be too complicated for the Wat Pathumwanaram School students and the surrounding community to understand and relate to. A cost effective garden is more practical in meeting the needs and limitations of the Wat Pathumwanaram School.

The garden design should be suitable for Bangkok.

Ajarn Tun expressed his concerns about the extreme weather conditions in Thailand, and Bangkok specifically. He made design suggestions for dealing with such weather conditions, most importantly the extreme heat. As a demonstration garden at a demonstration school in Bangkok, the aeroponic garden at the Wat Pathumwanaram School should be designed for success in Bangkok. With a target audience of students at the Wat Pathumwanaram School and surrounding community members in the city, the design should be relatable to Bangkok and successful in Bangkok. Making the garden design suitable for Bangkok functions two-fold, to

improve the functionality of the garden, and further show that soil-less agriculture is appropriate and a sustainable, self-sufficient practice for cities such as Bangkok.

4.4 Step 4: Developing Potential Aeroponic Garden Designs and Selecting a Feasible Solution

We developed more than one aeroponic garden design to give our project sponsor a choice and an understanding that there was more than one feasible solution. We designed three aeroponic systems based on the criteria. Each of the garden designs presented below demonstrate good practices in aeroponics, but range in cost and complexity.

Aeroponic Garden Design 1

The first garden design is a modular, four-unit tabletop design with a centralized reservoir for nutrient solution. The A-frame is constructed with aluminum and the reservoir is made from a durable plastic. Figure 4.1 shows aeroponic garden design 1.

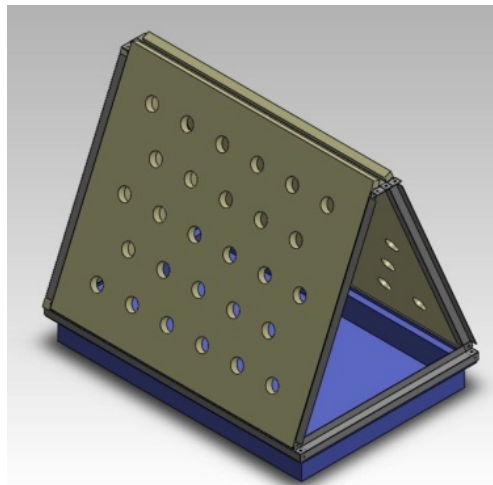

Figure 4.1: Aeroponic Garden Design 1

*Panels have been removed to show the inside of the garden.

Aeroponic garden design 1 has both advantages and disadvantages. Table 4.2 shows the advantages and disadvantages to this design as well as the total estimated cost of the system.

Table 4.2: Advantages and Disadvantages for Aeroponic Garden Design 1

<u>Advantages</u>	<u>Disadvantages</u>
<ul style="list-style-type: none"> • Small size makes cleaning easy • Small size allows it to be used by the students • External nutrient reservoir is easier to clean and check for pH and EC • Aluminum frame is durable to withstand weather in Bangkok • Parts are readily available in the city and not custom made which simplifies the construction • The design is vertical and suitable for cities such as Bangkok without much arable space 	<ul style="list-style-type: none"> • Higher initial start-up cost than design 3 • Metal frame requires welding which does not aid in the ease of construction • 4 units, causes more complicated plumbing
<p>Estimated Total Cost of System: 27,935 THB</p>	

From Table 4.2 it is important to notice that having an external nutrient solution container allows for easier cleaning and maintenance of the garden. It is also important to notice that the initial start up cost is higher than the third design, and multiple units will result in more complicated plumbing.

Aeroponic Garden Design 2

The second garden consists of two units that are larger and free standing with a self-contained reservoir for nutrient solution in each. The A-frame is constructed with aluminum and the reservoir is made from a durable plastic. Figure 4.2 shows aeroponic garden design 2.

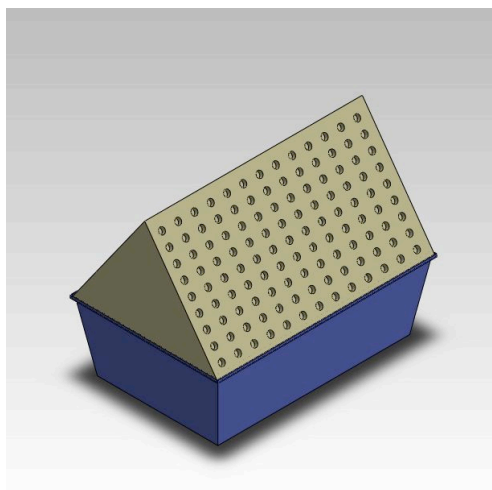

Figure 4.2: Aeroponic Garden Design 2

Aeroponic garden design 2 has both advantages and disadvantages. Table 4.3 shows the advantages and disadvantages to this design as well as the total estimated cost of the system.

Table 4.3: Advantages and Disadvantages for Aeroponic Garden Design 2

<u>Advantages</u>	<u>Disadvantages</u>
<ul style="list-style-type: none"> • The design is vertical and suitable for cities such as Bangkok without much arable space • Parts are readily available in the city and not custom made, which simplifies the construction • Two units, can be plumbed together fairly easily • Aluminum frame is durable to withstand weather in Bangkok 	<ul style="list-style-type: none"> • Highest initial start-up cost of all three designs • Internal nutrient reservoir makes it more difficult to clean • Metal frame requires welding which does not aid in the ease of construction
<p>Estimated Total Cost of System: 30,200 THB</p>	

From Table 4.3 it is important to notice that the use of two units can result in a higher yield of produce without resulting in complicated plumbing of the system. It is also important to notice that the initial cost for this garden design is the highest of the three designs.

Aeroponic Garden Design 3

The third garden is a single unit with a self-contained nutrient solution reservoir, and is overall a more simple design. The A-frame and reservoir are both made from wood. Figure 4.3 shows aeroponic garden design 3.



Figure 4.3: Aeroponic Garden Design 3

Aeroponic garden design 3 has both advantages and disadvantages. Table 4.4 shows the advantages and disadvantages to this design as well as the total estimated cost of the system.

Table 4.4: Advantages and Disadvantages for Aeroponic Garden Design 3

<u>Advantages</u>	<u>Disadvantages</u>
<ul style="list-style-type: none"> • The design is vertical and suitable for cities such as Bangkok without much arable space • Parts are readily available in the city and not custom made which simplifies the construction • One unit, has simple plumbing • Wooden frame is easiest to build and is very cost effective • Internal nutrient reservoir, compact design, useful for rooftops in Bangkok • Lowest start-up cost 	<ul style="list-style-type: none"> • Internal nutrient reservoir makes it more difficult to clean • Wooden frame is susceptible to water damage
<p>Estimated Total Cost of System: 20,077 THB</p>	

From Table 4.4 it is important to notice that this design has the lowest initial cost. The low initial cost is mainly due to the use of wood instead of aluminum for the gardens A-frame. A disadvantage to notice is the use of wood can make the frame susceptible to water damage. Water damage can occur if the wood is not properly sealed.

In consultation with our project liaison and school administration at the Wat Pathumwanaram School, aeroponic garden design 3 was chosen to be implemented at the Wat Pathumwanaram School. Figure 4.4 shows a model of the selected aeroponic garden design on the rooftop at the Wat Pathumwanaram School.

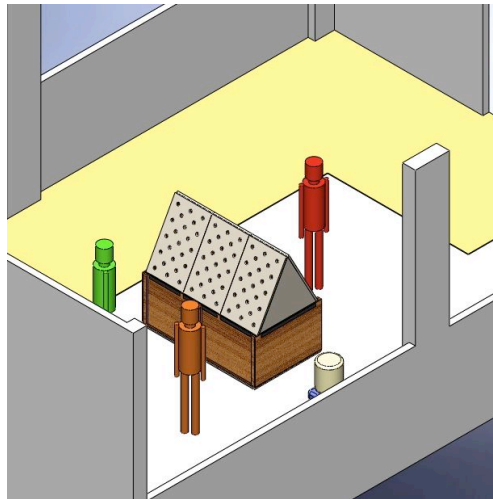

Figure 4.4: Model of Selected Aeroponic Garden Design

The third garden design was the strongest in meeting the design criteria and the needs of the Wat Pathumwanaram School. This design was the most cost effective design, as it was less expensive than the other two garden designs. The size of the third garden was appropriate and was a design that could be operated and maintained by the students at the Wat Pathumwanaram School. This design had the simplest plumbing of the three, and was the simplest to construct because it was made of a wooden frame instead of aluminum, which requires welding. The extreme temperatures of Bangkok were considered in this design, and it is reflected by the use of foam insulation throughout the design. Materials for this garden design could be found easily within Bangkok. As a demonstration garden, this design accurately demonstrates the soil-less agricultural technique of aeroponics, while being simple enough to be understood by the Wat Pathumwanaram School students and members of the surrounding community.

4.5 Step 5: Building the Aeroponic Garden, Transferring Plants, and Developing Construction and Maintenance Manuals

After receiving the necessary funding from our sponsor, the Wat Pathumwanaram School, and a third party sponsor, the Siam Kempinski Hotel, we constructed the chosen aeroponic garden (design 3).

We contracted an external company to construct the garden's A-frame and reservoir in order to save time and ensure high quality. The dimensions of the constructed reservoir and frame were influenced to be appropriately sized for easy maintenance and for the students at the Wat Pathumwanaram School to view. Due to its availability, low cost, and workability, we chose wood as the material for the frame and reservoir. We painted the constructed wood frame and reservoir with a white, oil-based paint. We chose white over a colored paint to absorb as little sunlight as possible to keep the garden cool. The paint was oil-based to seal the wood, preventing it from expanding due to moisture or humidity. We chose a high-density Styrofoam to insulate the reservoir of the garden from heat. To line the interior of the reservoir, we chose a durable black plastic both water-proofing the system and preventing leakage of the nutrient solution. The nutrient solution is sprayed from forty misters in order to ensure maximum coverage of plant roots. Viewing windows were cut on both sides of the garden for demonstration purposes. Those viewing the garden can remove the panels of the viewing windows to see the inside of the functioning garden. Overall, this garden design is appropriate for the demonstration of aeroponics and fulfills the defined design criteria of being easy to operate and maintain, cost effective, and suitable for Bangkok. For more specifics on the construction of the aeroponic garden, refer to Appendix D to view the construction manual. Figure 4.5 below is a photo of the completed garden.



Figure 4.5: Completed Aeroponic Garden

Our team had the necessary information to develop a feasible and appropriate aeroponic garden design, and because we had already built the aeroponic garden, we understood what the garden would require to remain in effective working order. Using this knowledge, we developed a maintenance manual to accompany the aeroponic garden which identifies and organizes the information necessary for sustaining and maintaining the aeroponic garden. Refer to Appendix E for the maintenance manual.

After construction, we transplanted seeded plants into the functioning aeroponic garden, but due to time constraints, we were only able to observe the beginning stages of the plant growth cycle. In Section 6.2 we provide our recommendations for the Wat Pathumwanaram School to assess the functionality of the aeroponic garden.

5.0 Objective 2: Developing Educational Material to Complement the Current Agricultural Curriculum at the Wat Pathumwanaram School

We developed educational material to complement the current agricultural curriculum at the Wat Pathumwanaram School in order to provide students with a more practical understanding of the hydroponic technology and other soil-less practices. To do this, we followed a curriculum development process, similar to the engineering design process used in Chapter 4.0, appropriate for achieving this objective at the Wat Pathumwanaram School. The steps in the process were:

1. Determining the educational goals for the developed material
2. Identifying the content to be covered by the developed material
3. Determining appropriate teaching methods for the developed material
4. Determining an appropriate approach for assessing the developed material
5. Developing educational material that complements the current agricultural curriculum at the Wat Pathumwanaram School

Below we elaborate on the steps in this process and how each step helped in achieving this project objective.

5.1 Step 1: Determining the Educational Goals for the Developed Material

Using a joint semi-structured interview with Ajarn Pataraporn and Ajarn Lalita we determined the educational needs of the Wat Pathumwanaram School, the educational needs of the students at the Wat Pathumwanaram School, and the educational goals and related objectives that the developed educational material should strive to meet. Both Ajarn Pataraporn and Ajarn Lalita stressed that the educational material should give students a more thorough and practical understanding of the details in hydroponics and the benefits of soil-less agriculture. These two sources were appropriate because they both understand the educational needs of the Wat Pathumwanaram School and the educational needs of the students at the Wat Pathumwanaram School. Refer to Appendix B.1 for the questions and responses gathered from this interview. The combination of these two interviews allowed us to identify a clear set of educational goals and

related objectives to achieve each goal. The determined educational goals and related objectives based on the interview responses are shown in Table 5.1.

Table 5.1: Educational Goals and Related Objectives for Developed Educational Material

Educational Goal	Educational Objectives
Students are actively involved with the educational material.	<ul style="list-style-type: none"> ○ Increased participation by the students in the classroom. ○ Overall attitude of the students seems positive. ○ Students enjoyed the educational material in comparison to the original material.
Students have a practical understanding of hydroponics.	<p>Students understand:</p> <ul style="list-style-type: none"> ○ The differences between soil-less agriculture and traditional agriculture ○ The benefits of hydroponics ○ How a hydroponic system works ○ System requirements (nutrient solution, pH, EC, maintenance).
Students have a practical understanding of the advantages of other soil-less agricultural techniques.	<p>Students understand:</p> <ul style="list-style-type: none"> ○ Other soil-less agricultural techniques ○ The overall benefits of soil-less agriculture especially in areas such as Bangkok

The educational objectives are measurable steps that can be taken to move towards achieving the educational goals. The three determined educational goals in Table 5.1 can be measured using

the related objectives, also shown in the table. Increased participation by students, a positive student attitude, and student preference of the developed material over the original material can be used to measure if students are interested and actively involved with the educational material. Student understanding of the differences between soil-less agriculture and traditional agriculture, the benefits of hydroponics, how a hydroponic system works, and hydroponic system requirements (nutrient solution, pH, EC, maintenance) can be used to measure if students have a practical understanding of hydroponics. Student understanding of other soil-less agricultural techniques and the overall benefits of soil-less agriculture in Bangkok can be used to measure if students have a practical understanding of the advantages of other soil-less agricultural techniques. Determining these educational goals sets a clear stage for what the developed material should strive to achieve for the Wat Pathumwanaram School and the students at the Wat Pathumwanaram School.

5.2 Step 2: Identifying the Content to be Covered by the Developed Material

We conducted a second semi-structured interview with Ajarn Lalita and identified the content in which she hoped to be covered by the developed educational material. The developed material was for Ajarn Lalita's class, so we valued her opinion on the content of the material. Refer to Appendix B.2 for the questions and responses gathered from this interview.

We also obtained the content and goals of the current agricultural curriculum for a general, required agriculture class and a more advanced, free elective agriculture class from Ajarn Lalita. The current agricultural curriculum informed us of what was currently being taught to the students about hydroponics and soil-less agriculture. Refer to Appendix F for the content and goals of the current agricultural curriculum at the Wat Pathumwanaram School for both the general class and the free elective class. We considered the content that Ajarn Lalita identified for inclusion in the developed material, the content and goals of the current agricultural curriculum, and the educational goals from Step 1, and identified the content the developed material should aim to cover. The content of the developed material should:

- Be focused for students at the seventh to ninth grade levels.
- Target both Ajarn Lalita's general, required agriculture course as well as the more advanced free elective course.
- Cover more thoroughly details in hydroponics that include preparing the nutrient solution and measuring the pH and EC values.
- Cover the benefits of soil-less agriculture techniques such as hydroponics.
- The content of the developed material should not drastically change the content of the current curriculum.

Be focused for students at the seventh to ninth grade levels.

Ajarn Lalita informed us that the students in seventh, eighth, and ninth grade are the students that will be required to go through the general agriculture course at the Wat Pathumwanaram School. She also explained that students at these grade levels are the only students with the option of the free elective course. With this in mind, the developed material should focus towards students at this level in school or else the material will be too difficult for its audience.

Target both Ajarn Lalita's general, required agriculture course as well as the more advanced free elective course.

Ajarn Lalita told us that she is responsible for the students in both the general and free elective courses, and that she is looking for improvements to both course curriculums. She said that she would welcome material that covered both general information as well as detailed information about hydroponics and soil-less agriculture. The developed material should adhere to both courses so students at all knowledge levels can benefit from the material and the practical understanding of soil-less agriculture it will strive to provide.

Cover more thoroughly details in hydroponics that include preparing the nutrient solution and measuring the pH and EC values.

Both Ajarn Pataraporn and Ajarn Lalita expressed concerns that most students, in addition to not understanding the steps in hydroponics, do not understand why the steps are important. Preparing the nutrient solution and measuring the pH and EC values are important steps in hydroponics, but it is also important for the students to understand why these steps must be followed for a more practical understanding. These steps in hydroponics are currently addressed in the curriculum, but students do not have a well enough understanding of these steps to be able to perform well on an exam. Understanding why the steps in hydroponics are important contributes to a more practical understanding of hydroponics.

Cover the benefits of soil-less agriculture techniques such as hydroponics.

Both Ajarn Pataraporn and Ajarn Lalita brought to our attention that students do not understand why soil-less agriculture is beneficial. As a demonstration school, the Wat Pathumwanaram School is working to diversify its soil-less agricultural program to demonstrate soil-less agriculture as a sustainable and self-sufficient practice. Students at the Wat Pathumwanaram School should have a more practical understanding of soil-less agriculture and its benefits to understand how soil-less techniques are significant and appropriate for Bangkok.

The content of the developed material should not drastically change the content of the current curriculum.

The developed educational material would complement the current curriculum, and the content of the developed material would be content that is familiar to Ajarn Lalita. In their report for the U.S. Office of Education, Berman and McLaughlin (1978) claim that introducing drastic changes to a curriculum has been shown to be less effective than working with an educator to slowly make changes. If the material was changed drastically it would not be used because it would not fit with the current overall organization of the curriculum, and would be out of place.

5.3 Step 3: Determining Appropriate Teaching Methods for the Developed Material

In the same semi-structured interview conducted in Step 2 with Ajarn Lalita, we identified her classroom preferences and the current teaching method(s) used in her agriculture class. We also

conducted a semi-structured interview with Ajarn Monlada Sukalarm and gained a stronger understanding of typical teaching methods at the Wat Pathumwanaram School and suggestions on how to tailor any newly developed educational material to teaching methods used at the school. Refer to Appendix B.2 for questions and responses from the interview with Ajarn Lalita, and refer to Appendix B.3 for questions and responses from the interview with Ajarn Sukalarm.

Our extensive background research on various teaching methods strongly supports the use of active learning and visual learning as good teaching approaches. See Section 2.5 for further information and background research on various teaching methods, specifically active learning, Section 2.5.1, and visual learning, Section 2.5.3.

We considered the interview responses by Ajarn Lalita and Ajarn Monlada Sukalarm, the valuable information from our background research, and the educational goals from Step 1, and determined appropriate teaching methods and approaches for the developed material.

- Must not introduce radical changes to the current teaching style.
- The use of PowerPoint.
- The use of visuals.
- Integrate methods of active learning into the developed material.

Must not introduce radical changes to the current teaching style.

When asked, Ajarn Lalita told us that her primary teaching methods are lectures that incorporate PowerPoint presentations. Ajarn Lalita seemed reluctant to make changes to her current teaching style. To re-iterate what was stated by Berman and McLaughlin, introducing radical changes into a curriculum has been shown to be less effective. Ajarn Monlada Sukalarm informed us that teachers at the Wat Pathumwanaram School typically use lectures because it is easier to control the large class sizes. She informed us that the teachers are often not uncomfortable changing their teaching style, and suggested that we do not develop material that requires a drastic change. Creating educational materials that work well with the current teaching style will allow an easier adjustment for Ajarn Lalita, and can better sustain the use of the developed material because Ajarn Lalita will not be altering her teaching method.

The use of PowerPoint.

As stated above, Ajarn Lalita primarily uses PowerPoint based lectures in her class, with minimal use of demonstrations and hands-on interactions with plants. PowerPoint can be used for in-class lectures and to prompt an in-class activity that can be more active or involved for the students in the classroom. The use of PowerPoint can be a good way to present material to students without drastically changing the teachers teaching style.

The use of visuals.

Ajarn Lalita expressed that she wanted ways to engage her students and increase their interest in the agriculture class. She also said that the use of the rooftop where the aeroponic garden is located would be a good aspect to incorporate into her class, and a good visual for her students. According to Lowe, including visuals can be beneficial to teaching concepts that are difficult and complex. The use of visuals can be beneficial to students at the Wat Pathumwanaram School in understanding the sometimes complex topic of soil-less agriculture. Visuals can help improve understanding by presenting the material in a different way. Using visuals can draw the attention of students as they are typically interesting, incorporate color, and use pictures, aspects that are engaging to students. Students at the Wat Pathumwanaram School can benefit from the use of visuals in the agricultural curriculum as they would be a good method of not only catching their attention on the subject matter, but can help improve their understanding of soil-less agriculture.

Integrate methods of active learning into the developed material.

According to Benware and Deci, active learning has been shown to increase student engagement in their education, increase conceptual learning, and promote long-lived conceptual understanding. Smith and MacGregor support collaborative learning and how it can increase student participation and enthusiasm for the material. According to Marangos, collaborative learning has been shown to increase active participation in class. A case by Stajano was an example of active learning successfully used as a teaching approach for agriculture. A study by Mabie looked at the benefits of incorporating agricultural activities in the classroom.

Incorporating these active learning methods has potential for success in reaching the personal goals set by Ajarn Lalita and the identified educational goals. Students can gain a more practical understanding of hydroponics through student/classroom engagement.

5.4 Step 4: Determining an Appropriate Approach for Assessing the Developed Material

We determined an appropriate approach for assessing the developed educational material using the same semi-structured interview conducted in Step 2 with Ajarn Lalita. We determined that Ajarn Lalita's primary method for assessing her students is through written exams. Refer to Appendix B.2 for questions and responses from this interview. As explained above in section 5.1, her educational goals for the students include active participation in the material, a practical understanding of hydroponics, and the practical understanding of the advantages of soil-less agriculture. Ajarn Lalita's current method for assessing her students and the defined educational goals were considered in the following approach for assessment.

The developed educational materials should be assessed by measuring whether they achieve the identified educational goals.

According to Howard, educational goals identify what educators seek to teach their students and later allow for the assessment of the effectiveness of the education and whether or not the goals were met. The educational objectives that were developed in section 5.1 and outlined in Table 5.1 are measurable so the agriculture teacher, Ajarn Lalita, can understand if the developed material is contributing in achieving them. The questions below in Table 5.2 are some that the agriculture teacher can answer to measure how the objectives, and ultimately the educational goals, are being met.

Table 5.2: Educational Goals and Questions to Consider to Determine if Goals were Achieved

Educational Goal	Questions to Consider for Assessment
Students are actively involved with the educational material.	<ul style="list-style-type: none"> ○ Is there an increased participation by the students in the classroom? ○ Does the overall attitude of the students seem positive? ○ Did students enjoy the educational material in comparison to the original material?
Students have a practical understanding of hydroponics.	<ul style="list-style-type: none"> ○ Do students understand the differences between soil-less agriculture and traditional agriculture? ○ Do students understand the benefits of hydroponics? ○ Do students understand how a hydroponic system works and the system requirements (nutrient solution, pH, EC, maintenance)?
Students have a practical understanding of the advantages of other soil-less agricultural techniques.	<ul style="list-style-type: none"> ○ Do students understand other soil-less agricultural techniques? ○ Do students understand the overall benefits of soil-less agriculture especially in areas such as Bangkok?

As shown in Table 5.2, to assess the accomplishment of the first educational goal, the teacher should probe student participation and overall attitude towards the material. To assess the accomplishment of the second educational goal, the teacher should measure whether the students can distinguish between soil-less and traditional agriculture, the benefits of hydroponics, how a hydroponic system works, and hydroponic system requirements. To assess the accomplishment

of the third educational goal, the teacher should evaluate the students' understanding of other soil-less agricultural techniques as well as their understanding of the benefits of soil-less agriculture.

Assessing the developed material is important for understanding whether the materials are effective. Polich and Goodell say that assessment is significant because it can be used to gauge the students' retention of the developed material and whether or not the educational goals were achieved. Most importantly, the assessment of the effects of developed material is important so that future recommendations for improvement can be made. The Wat Pathumwanaram School is looking for growth and improvement to its agricultural curriculum, and will be welcoming to recommendations for future improvements.

5.5 Step 5: Developing Educational Material that Complements the Current Agricultural Curriculum at the Wat Pathumwanaram School

We created a comparison chart to organize all of our gathered information from steps 1-4, refer to Appendix C.2. Based on all of our gathered information and previous claims and reasoning in Steps 1-4, we knew that the developed material had to:

- Strive to achieve the determined educational goals.
- Be targeted for its audience: 7th, 8th, and 9th grade students at the Wat Pathumwanaram School and students in the general, required agriculture class as well as the free elective class.
- Cover the same content as the current agricultural curriculum.
- Compliment the current teaching method used by the agricultural teacher.
- Incorporate active learning and visuals.

We reformatted and re-designed current PowerPoint presentations used in the agriculture class and also created four additional PowerPoint presentations covering material that is typically in a lecture, we created a soil-less agriculture “Jeopardy” game, and we developed soil-less agriculture posters for the same rooftop that the aeroponic garden was constructed on. As

described below, the development of these educational materials can be used to improve the student’s academic experience in the agriculture class.

We reformatted and re-designed current PowerPoint presentations used in the agriculture class and also created four additional PowerPoint presentations covering material that is typically in a lecture.

We re-formatted and redesigned Ajarn Lalita’s current “Hydroponics” and “Materials Used” PowerPoint presentations to be visually appealing and interactive to interest the students, and more clearly organize the material. Re-formatting and re-designing the current PowerPoint presentations used in the agriculture class complements the current teaching style of Ajarn Lalita, and does not result in any loss of content. We also created four new PowerPoint presentations for “Soil-less Agriculture,” “Aeroponics,” “Substrate Culture,” and “Nutrient Solution.” Figure 5.1 is an example of one of the presentation slides from the “Soil-less Agriculture” PowerPoint.



Figure 5.1: Example Slide from Soil-less Agriculture PowerPoint Presentation

Creating additional PowerPoint presentations for topics in the curriculum that are currently in a simple lecture format will provide a better visual and aid for the students. All of the PowerPoint presentations incorporate pictures and other graphics to explain topics in soil-less agriculture. According to Lowe using pictures and graphics to explain technical ideas to students can be very beneficial. The PowerPoint presentations are not only good visuals for students, but they have the potential to increase student interest, cover details on a wide range of topics in soil-less agriculture, and are appropriate for the general, required agriculture class. The re-formatted and re-designed presentations and the newly developed PowerPoint presentations have the potential to increase student interest to allow for a more practical understanding of not only hydroponics, but soil-less agriculture. Refer to Appendix G.1 for an example comparing the previous PowerPoint slides to the reformatted and re-designed slides, and for example slides from the newly developed PowerPoints.

We created a soil-less agriculture “Jeopardy” game.

The creation of the soil-less agriculture jeopardy game exemplifies an activity that incorporates active learning and has the potential to increase student involvement. According to a study by Steve Higgins, Heather Smith, and Kate Wall professors at New Castle University (2005), “The use of games was indicated as having an important influence in supporting and maintaining the learning process. Pupils talked about how games made learning fun, easier, and changed their conception of specific subjects.” We chose to develop a game because it can be a fun and involving in-class activity for the students. In addition, this game does not alter the current content of the curriculum, but is rather a review of all of the content in the curriculum. We made the game using PowerPoint, and therefore the game is prompted using a teaching aid that is familiar to the agriculture teacher. Figure 5.2 is the main game board for the soil-less agriculture game.

Soil-less agriculture				
Equipment Used	Steps of Soil-less culture	Soil-less farming techniques	Plants	Caring for Plants
<u>10</u>	<u>10</u>	<u>10</u>	<u>10</u>	<u>10</u>
<u>20</u>	<u>20</u>	<u>20</u>	<u>20</u>	<u>20</u>
<u>30</u>	<u>30</u>	<u>30</u>	<u>30</u>	<u>30</u>
<u>40</u>	<u>40</u>	<u>40</u>	<u>40</u>	<u>40</u>
<u>50</u>	<u>50</u>	<u>50</u>	<u>50</u>	<u>50</u>

Figure 5.2: Main Game Board for Soil-less “Jeopardy” Game

The game requires teamwork and collaboration, and covers topics on hydroponics and general soil-less agriculture. The questions are angled to be simpler to adhere to the general, required agricultural class, however the way the game is designed, it can be updated to be appropriate for students at varying knowledge levels. Refer to Appendix G.2 for the example questions and answers that are included in this game.

We developed soil-less agriculture posters for the rooftop.

On the rooftop where the aeroponic garden was constructed, there are other demonstration gardens (substrate culture and deep flow technique) in addition to constructed aeroponic garden. We developed visuals for the three different types of soil-less agricultural techniques demonstrated on the rooftop to help students understand the many types of soil-less agricultural techniques. We also developed a general poster that explains the categories under soil-less agriculture (hydroponics, aeroponics, and substrate culture). To re-iterate, according to Lowe including visuals can be beneficial to teaching concepts that are difficult and complex, such as different techniques in soil-less agriculture. Figure 5.3 is the general soil-less agriculture poster for the rooftop.

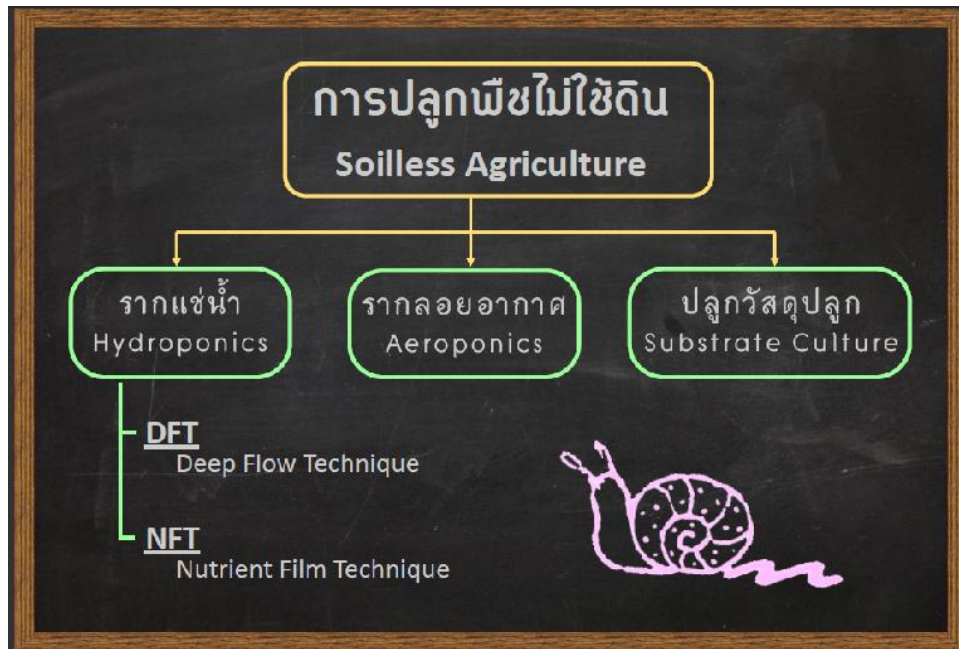

Figure 5.3: Soil-less Agriculture Poster

Using the rooftop and the posters showing the different soil-less techniques is appropriate for the general agriculture class as well as the free elective course. The posters provide information that explains different soil-less techniques to the students while they observe the techniques or work actively operating and maintaining the gardens on the rooftop. The presentation of the material and topics using posters, a different way than what the students are used to, can be beneficial to all students to better understand soil-less agriculture and the many practices. Refer to Appendix G.3 for examples of the developed posters.

The three developed materials above have the potential to improve the learning experience of the agriculture students at the Wat Pathumwanaram School. The materials either incorporate active learning or visual learning; two methods of teaching that have shown to be good methods for improving student learning. All of the developed material, together, contributes towards further improving the soil-less agriculture program at the Wat Pathumwanaram School. Due to time constraints, we were not able to implement any of the developed educational material. In Section 6.3 we provide recommendations for the incorporation of the developed material into the current agricultural curriculum at the Wat Pathumwanaram School.

6.0 Conclusions and Recommendations

Based on the analysis of the gathered information and findings, we developed conclusions and recommendations that correspond to both the demonstration aeroponic garden and developed educational materials, as well as developing the Wat Pathumwanaram School's comprehensive agricultural program.

6.1 Overall Project Conclusions

The constructed aeroponic garden for this project demonstrates a different type of sustainable soil-less agricultural practice for the students at the Wat Pathumwanaram School and the surrounding community. It was designed to be simple to operate and maintain, cost effective, and suitable for sustaining in Bangkok. The newly developed educational material was designed to complement the current agricultural curriculum at the Wat Pathumwanaram School. It incorporates both active and visual learning and has the potential to provide students with a more practical understanding of soil-less agriculture. Together, these two objectives achieve our greater project goal. We have made contributions to assisting the Wat Pathumwanaram School in developing its comprehensive agricultural program in order to demonstrate how soil-less agricultural techniques are sustainable and self-sufficient technologies.

The following two sections state and discuss further recommendations for the Wat Pathumwanaram School relating to both of our project objectives. In relation to the constructed aeroponic garden, by following these recommendations the Wat Pathumwanaram School can assess its functionality and work towards properly sustaining and maintaining the system. In relation to the developed educational material, by following these recommendations, the Wat Pathumwanaram School can work to incorporate and assess the material that was developed for the agricultural curriculum.

6.2 Assessing and Sustaining the Aeroponic Garden at the Wat Pathumwanaram School

Before leaving, we tested the aeroponic garden and concluded that the parts were properly functioning together to create a working unit. We tested the system with nutrient solution and transplanted seeded plants into the system; however, there was not enough time to evaluate the plants for a full growth cycle. The recommendations for assessing and sustaining the aeroponic garden are the next appropriate steps to take in the demonstration of aeroponics.

- We recommend that the functionality of the aeroponic system be assessed.
- We recommend that the Wat Pathumwanaram School install the ordered timer for the system.
- We recommend that if an expert opinion or assistance is required for the aeroponic garden, Ajarn Tun is contacted.
- We recommend that the rooftop be used to demonstrate various types of soil-less agricultural techniques.

We recommend that the functionality of the aeroponic system be assessed.

Assessing the functionality will allow the school to determine if the aeroponic system has met its purpose as a demonstration garden. It is important that the aeroponic system be in good working order for a successfully functioning garden that can be considered a good example and representation of a soil-less agricultural technique. Answers to the following questions can lead to the determination of whether or not the aeroponic garden is properly functioning and, if necessary, will allow the Wat Pathumwanarm School to identify any improvements to be made.

How well is the system working?

The Wat Pathumwanaram School can determine if the aeroponic system is working effectively by speaking with the the Wat Pathumwanaram School custodian, Ajarn Lalita, and Ajarn Tun. When the system is in use, the Wat Pathumwanaram School can speak with any of these three sources and ask opinions on how well the system is working. If the system is not working

properly, or if it is not being used in general, the reasons why are very important to determine so the school can work towards addressing these issues and finding a solution.

How efficiently has the system been growing vegetables?

The Wat Pathumwanaram School can determine the efficiency of the aeroponic garden by keeping record of the plant growth in the system. Aeroponics typically results in faster plant growth over hydroponics; therefore, the Wat Pathumwanaram School can compare the yield from the aeroponic garden to that of the hydroponic garden on the other rooftop at the school. The Wat Pathumwanaram School should know this information to guide their decision to continue, modify, expand, or stop using the system.

We recommend that the Wat Pathumwanaram School install the ordered timer for the system.

We ordered a 24 volt timing system for the aeroponic garden, but it was not scheduled to arrive until after the project. It would be a good strategy for the Wat Pathumwanaram School to install this timer. The timing system will turn the pressurized pump on and off, automatically, controlling when and for how long the nutrient solution is sprayed onto the plant roots. This will save on electricity costs in the long run, and is a good way to ensure that the roots of the plants are not under/over exposed to the nutrient solution.

We recommend that if an expert opinion or assistance is required for the aeroponic garden, Ajarn Tun is contacted.

Ajarn Tun has a strong relationship with the Wat Pathumwanaram School and is very knowledgeable in soil-less agriculture and would be a valuable resource for contact by the school if necessary. Ajarn Tun was an invaluable resource for our project team in the design and construction of the aeroponic garden. Because our project team will not be available after the completion of the project, Ajarn Tun is a qualified resource for questions and concerns about the garden.

We recommend that the rooftop be used to demonstrate various types of soil-less agricultural techniques.

To increase the reputation of the Wat Pathumwanaram School as a demonstration school, we strongly encourage it to use the rooftop that the constructed aeroponic garden is on as a rooftop to demonstrate multiple techniques in soil-less agriculture. In addition to the newly constructed aeroponic garden, there are deep flow systems and two substrate culture systems. All of these systems are functioning, able to sustain the growth of plants, and able to act as appropriate demonstration tools for soil-less agriculture. The use of multiple types of soil-less techniques is a more powerful demonstrational tool.

6.3 Incorporating and Assessing the Developed Educational Material

We were not able to incorporate any of the developed educational material into the agricultural curriculum. We have made recommendations for the incorporation of the three developed educational materials into the current agricultural curriculum at the Wat Pathumwanaram School. We focused on when the material could be incorporated into the curriculum, how the material could be used, and why it should be used. We were not able to assess any of the developed educational material. We have left recommendations for an appropriate approach to be used in assessing the material after it has been implemented. The recommendations for incorporating and assessing the developed material are the next appropriate steps to be taken at the Wat Pathumwanaram School.

- The reformatted and re-designed PowerPoint presentations and the created four additional PowerPoint presentations can be used to compliment current lecture materials.
- The soil-less agriculture “Jeopardy” game is interactive and can be used as an examination review for students.
- The soil-less agriculture posters for the rooftop can be used to demonstrate different soil-less techniques.
- We recommend that the developed educational material be assessed to ensure it achieves the identified educational goals.
 - Goal 1: Students are actively involved with the educational material.

- Goal 2: Students have a practical understanding of hydroponics.
- Goal 3: Students have a practical understanding of the advantages of other soil-less agricultural techniques.

The reformatted and re-designed PowerPoint presentations and the created four additional PowerPoint presentations can be used to compliment current lecture materials.

The Wat Pathumwanaram School can use the re-formatted and re-designed PowerPoint presentations as a substitute to the original presentations in the general agriculture class without loss of content. The Wat Pathumwanaram School can use the newly created PowerPoint presentations to present traditional lecture material to students in a method that the agricultural teacher is comfortable with. All of the PowerPoint presentations involve animations, clear visuals, and pictures to peak student interest. The use of animations and pictures can assist in explaining the details of soil-less agriculture to students. We encourage that these presentations be incorporated into the curriculum because they have the potential to increase student attention in the classroom, allowing them to absorb and understand more of the material.

The soil-less agriculture “Jeopardy” game can be used as an examination review for students.

The agriculture teacher at the Wat Pathumwanaram School can use this game a day or two before an examination to act as a review for the students. The agriculture teacher can split the class into groups or teams before playing the game. This will promote collaboration between students, which has been shown to improve student participation and learning. The groups should consist of students with varying knowledge levels because combining students of varying knowledge levels has been shown to increase student learning. This game focuses mainly on hydroponics, but includes some information about soil-less agriculture as well. Questions are based on topics covered in the class, and the course syllabus is heavily referenced. The question’s difficulty range is appropriate for students in the general agriculture class, but the template used for the game can be used to increase the difficulty level of the questions for students at varying knowledge levels (students in the free elective class). This in-class game has the potential to

increase student learning through fun, active, and team based learning, all methods supported as being beneficial to students. Specific to the Wat Pathumwanaram School, this game has the potential to give students a more practical understanding of hydroponics and soil-less agriculture.

The soil-less agriculture posters for the rooftop can be used to demonstrate different soil-less techniques.

The agriculture teacher can take her students to the rooftop to see the demonstration of three different soil-less agricultural techniques. The soil-less agriculture posters will be permanently on the rooftop and able to be viewed at any time. A visual aid to accompany a soil-less technique can make it easier for students to understand the technique. It is beneficial for students to see the demonstration of three different soil-less techniques to understand that there are many practices that can be used for soil-less agriculture. When the subject of a soil-less techniques comes up in class, the teacher can take the students to the rooftop. The posters will show the students the details of each technique. Additionally, the students will be able to see a real-life model of each technique.

We recommend that the developed educational material be assessed to ensure it achieves the identified educational goals.

Successful educational material achieves the educational goals that were identified prior to the development of the material. With this in mind, after incorporating the developed material into the current curriculum we recommend that the Wat Pathumwanaram School follow our recommended approach for assessing the developed material to determine if the material met the identified educational goals. Assessment is also significant because it can be used to gauge the students' retention of the developed material and whether or not the educational goals were achieved. Most importantly, the assessment on the effects of developed material is important so that future improvements can be made.

The Wat Pathumwanaram School should use their current methods of assessment in answering the following questions to avoid changing two variables, risking the uncertainty of which affects

the overall outcome. Answers to the following questions can lead to the determination of whether or not the educational goals have been achieved.

Goal 1: Students are actively involved with the educational material.

Is there an increased participation by the students in the classroom?

Ajarn Lalita and the Wat Pathumwanaram School can determine if there is an increased participation by students in the classroom. An increased participation can mean that the students are more interested and actively involved with the material.

Does the overall attitude of the students seem positive?

Ajarn Lalita and the Wat Pathumwanaram School can determine if the overall attitude of the students is positive towards the developed material. If the students are excited about the new material, they are most likely actively involved in the class.

Did students enjoy the educational material in comparison to the original material?

Ajarn Lalita and the Wat Pathumwanaram School can determine if the students enjoyed the developed educational material more than the original material. The opinion of the students is significant and if they agree that they prefer the developed material over the original material, this response weighs heavily in deciding the effectiveness of the material.

The answers to these questions can be used to measure if the educational material promotes active participation and involvement by students. The answers can also be used to guide adjustment of the developed materials as well as the creation of additional materials.

Goal 2: Students have a practical understanding of hydroponics.

Do students understand the differences between soil-less agriculture and traditional agriculture, the benefits of hydroponics, how a hydroponic system works, system requirements (nutrient solution, pH, EC, maintenance)?

Ajarn Lalita and the Wat Pathumwanaram School can determine if the students in the agriculture class have a practical understanding of hydroponics as a whole by determining if they understand the basics of soil-less agriculture, the benefits of hydroponics, and the smaller, important steps to hydroponics.

The answer to this question can be used to measure if the educational material has contributed to providing students with a more practical understanding of hydroponics. The answers can also be used to guide adjustment of the developed materials as well as the creation of additional materials.

Goal 3: Students have a practical understanding of the advantages of other soil-less agricultural techniques.

Do students understand other soil-less agricultural techniques and the overall benefits of soil-less agriculture especially in areas such as Bangkok?

Ajarn Lalita and the Wat Pathumwanaram School can determine if the students in the agriculture class have a practical understanding of the advantages of other soil-less techniques by determining if the students understand other soil-less techniques and the overall benefits of soil-less agriculture.

The answer to this question can be used to measure if the educational material has contributed to providing students with a more practical understanding of the advantages of other soil-less techniques. The answers can also be used to guide adjustment of the developed materials as well as the creation of additional materials.

The constructed aeroponic garden and developed educational material are further additions to strengthen the current soil-less agricultural program at the Wat Pathumwanaram School. By considering our recommendations above, the Wat Pathumwanaram School can take the next steps in fully developing its comprehensive soil-less agricultural program.

References

- Benware, C. A., & Deci, E. L. (1984). Quality of learning with an active versus passive motivational set. *American Educational Research Journal*, 21(4), pp. 755-765. Retrieved from <http://www.jstor.org/stable/1162999>
- Berg, B. L. (2007). *Qualitative research methods for the social sciences* (Sixth ed.). Boston: Allyn & Bacon.
- Berman, P., & McLaughlin, M. W. (1978). Federal programs supporting education change, vol. VIII: Implementing and sustaining innovations.
- Bernhard, J. (2010). Does active engagement curricula give long-lived conceptual understanding? Retrieved from http://webstaff.itn.liu.se/~jonbe/fou/didaktik/papers/girep2000_active.pdf
- Bollag, B. (2003). Study documents economic benefits of secondary and higher education in the developing world. *The Chronicle of Higher Education*, Retrieved from <http://www.nyu.edu/classes/jepsen/chronicleFeb1903.pdf>
- Central Intelligence Agency. (2011). *CIA - the world factbook*. Retrieved 2/7, 2011, from <https://www.cia.gov/library/publications/the-world-factbook/geos/th.html>
- Chung, C., Ritoper, S., & Takemoto, S. (2010). *Case study: Bangkok and access to food for Low - Income residents*. Massachusetts Institute of Technology. Retrieved from http://colabradio.mit.edu/~alexam/colabradio/wp-content/uploads/2010/01/CaseStudy_Bangkok_Food_Access.pdf
- Doise, W. W. (1975). Social interaction and the development of cognitive operations. *European Journal of Social Psychology*, 5(3), 367-383.
- Gervais, S. (2011). *Personal interview*. Hydroponic Expert.
- Gijlers, H., & De Jong, T. (2005). The relation between prior knowledge and students' collaborative discovery learning process. *Journal of Research in Science Teaching*, 42(3), 264. Retrieved from http://doc.utwente.nl/53713/1/Gijlers,_2005,_The_relation.pdf
- Growshop.com. (2010). *Aeroponics*. Retrieved 12/6, 2010, from <http://www.growshop.com/hydroponic-systems/aeroponics/aeroponics.html>
- Haapala, U. (2002). *Urbanization and water: The stages of development in latin america, south-east asia and west africa*. Helsinki University of Technology.

- Hake, R. R. (1998). Interactive-engagement versus traditional methods: A six-thousand-student survey of mechanics test data for introductory physics courses. *American Journal of Physics*, 66, 64.
- Hara, Y., Takeuchi, K., & Okubo, S. (2005). Urbanization linked with past agricultural landuse patterns in the urban fringe of a deltaic asian mega-city: A case study in bangkok. *Landscape and Urban Planning*, 73(1), 16-28. Retrieved from http://www.sciencedirect.com/science?_ob=ArticleURL&_udi=B6V91-4DFX39W-1&_user=74021&_coverDate=08%2F15%2F2005&_rdoc=1&_fmt=high&_orig=search&_origin=search&_sort=d&_docanchor=&view=c&_searchStrId=1534440903&_rerunOrigin=scholar.google&_acct=C000005878&_version=1&_urlVersion=0&_userid=74021&md5=5437e87fea2f41abad35102bbfb4a62a&searchtype=a
- He, J. J., Lee, S. K., & Dodd, I. C. (2001). Limitations to photosynthesis of lettuce grown under tropical conditions: Alleviation by root-zone cooling. *Journal of Experimental Botany*, 52(359), 1323-1330.
- Higgins, S., Smith, H., & Wall, K. (2005). 'The visual helps me understand the complicated things': Pupil views of teaching and learning with interactive whiteboards. *British Journal of Educational Technology*, 36(5), 851. Retrieved from <http://davidlongman.com/documents/Interactive%20Whiteboards/thevisualhelpsmeunderstand.pdf>
- Hopkins, W. G., & Hüner, N. P. A. (2004). *Introduction to plant physiology* (3rd ed.). Hoboken, NJ: J. Wiley. Retrieved from <http://www.loc.gov/catdir/toc/wiley041/2002192271.html>; <http://www.loc.gov/catdir/description/wiley037/2002192271.html>
- Howard, J. (2007). *Curriculum development*. Department of Education, Elon University. Retrieved from <http://org.elon.edu/catl/documents/curriculum%20development.pdf>
- Hung, D. (2002). Situated cognition and problem-based learning: Implications for learning and instruction with technology. *Journal of Interactive Learning Research*, 13(4), 393-414. Retrieved from <http://www.editlib.org/p/9176>
- Hynes, M. M. (2010). Middle-school teachers' understanding and teaching of the engineering design process: A look at subject matter and pedagogical content knowledge. *International Journal of Technology and Design Education*, Retrieved from <http://www.springerlink.com/content/ypt718n725657224/>

- Jirojvongse, P. (2011). *Personal interview*. Wat Pathumwanaram School.
- Jones, J. B. (1997). *Hydroponics : A practical guide for the soilless grower*. Boca Raton, Fla.: St. Lucie Press.
- Jongkroy, P. (2009). Urbanization and changing settlement patterns in peri-urban bangkok. *Kasetsart Journal*, (30), 303. Retrieved from <http://www.thaiscience.info/journals/Article/Urbanization%20and%20changing%20settlement%20patterns%20in%20peri-urban%20bangkok.pdf>
- Joyce, B. (2007). *Developing a competency based curriculum*. Unpublished manuscript. Retrieved 1/26, 2011, from www.acgme.org/outcome/e-learn/redirect_module4.asp
- Kelting-Gibson, L. M. (2005). Comparison of curriculum development practices. *Educational Research Quarterly*, 29(1), 26. Retrieved from <http://www.eric.ed.gov/PDFS/EJ718116.pdf>
- Khandani, S. (2005). Engineering design process. *Industry Initiative for Science and Math Education, Solectron* Retrieved from <http://www.iisme.org/etp/HS%20Engineering-%20Engineering.pdf>
- Klahr, D., & Nigam, M. (2004). The equivalence of learning paths in early science instruction: Effects of direct instruction and discovery learning. *Psychological Science*, 15(10), pp. 661-667. Retrieved from <http://www.jstor.org/stable/40064024>
- Lowe, R. (2000). Visual literacy and learning in science. *ERIC Digest*, 11 Retrieved from <http://www.ericdigests.org/2003-1/visual.htm>
- Mabie, R. (1996). A comparison of experiential instructional strategies upon the science process skills of urban elementary students. *Journal of Agricultural Education*, 37, 1.
- Marangos, J. (2000). The effectiveness of collaborative problem solving tutorials in introductory microeconomics. [The Effectiveness of Collaborative Problem Solving Tutorials in Introductory Microeconomics] Retrieved from <http://www.soc.uoc.gr/marangos/pdf/02-2000-Economic%20Papers.pdf>
- Matuschke, I. (2009). *Rapid urbanization and food security: Using food density maps to identify future food security hot spots*. Food and Agricultural Organization of the United Nations.
- Mayer, R. E. (2004). Should there be a three-strikes rule against pure discovery learning? the case for guided methods of instruction. *American Psychologist*, 59(1), 14. Retrieved from <http://www.katharinewoman.com/Research/Desktop/amp-59-1-14.pdf>

- Munson, S. (2001). *MarsPort 2002: An evolutionary deployable greenhouse for mars*. Needham, Massachusetts: Franklin W Olin College of Engineering. Retrieved from <http://projects.olin.edu/marsport/cdr.pdf>
- National University of Singapore. (2000). *Aero-green aeroponics farm*. Retrieved 1/17, 2011, from http://www.usp.nus.edu.sg/global_programme/studentwork/sungei/aero.htm
- Norman, G. R. (1992). The psychological basis of problem-based learning: A review of the evidence. *Journal of Medical Education*, 67(9), 557.
- Nuntagij, I. (2011). *Personal interview*. King Mongkut's Institute of Technology Ladkrabang.
- Polich, S., & Goodell, Z. (2007). *New faculty resource guide*. Virginia Commonwealth University Center for Teaching Excellence. Retrieved from <http://www.vcu.edu/cte/resources/nfrg/index.htm>
- Prasart, L. (2011). *Personal interview*. Wat Pathumwanaram School.
- Redish, E. F., Saul, J. M., & Steinberg, R. N. (1997). *On the effectiveness of active-engagement microcomputer-based laboratories* Retrieved from http://find.galegroup.com/gtx/infomark.do?&contentSet=IAC-Documents&type=retrieve&tabID=T001&prodId=AONE&docId=A19129435&source=gale&srcprod=AONE&userGroupName=mlln_c_worpoly&version=1.0
- Resh, H. M. (1995). *Hydroponic food production : A definitive guidebook of soilless food-growing methods* (5th ed.). Santa Barbara, Calif.: Woodbridge Press Pub. Co.
- Smith, B. L., & MacGregor, J. T. (1992). What is collaborative learning? In *Collaborative learning: A sourcebook for higher education* (pp. 10). University Park, Pennsylvania: National Center on Post-Secondary Teaching, Learning, and Assessment. Retrieved from <http://eric.ed.gov/PDFS/ED357705.pdf>
- Stajano, M. C. (2004). *Simplified hydroponics for kindergartens*. Retrieved 11/14, 2010, from <http://www.cityfarmer.org/hydroUruguay.html>
- Sukalarm, M. (2011). *Personal interview*. Wat Pathumwanaram School.
- Suteethorn, K. (2009). Urban agriculture: Ecological functions for urban landscape. Retrieved from http://www.land.arch.chula.ac.th/data/file_20091118100206.pdf
- Terenzini, P. T. (2001). Collaborative learning vs. Lecture/Discussion: Students' reported learning gains. *Journal of Engineering Education (Washington, D.C.)*, 90(1), 123.

- The Weather Channel. (2011). *Average weather for bangkok - temperature and precipitation*. Retrieved 2/28, 2011, from <http://www.weather.com/outlook/travel/businesstraveler/wxclimatology/monthly/graph/THXX0002>
- The World Bank Group. (2009). *Education - education for the knowledge economy*. Retrieved 11/23, 2010, from <http://web.worldbank.org/WBSITE/EXTERNAL/TOPICS/EXTEDUCATION/0,,contentMDK:20161496~menuPK:540092~pagePK:148956~piPK:216618~theSitePK:282386,00.html>
- The World Bank Group. (2010). *Education - secondary education*. Retrieved 11/23, 2010, from <http://web.worldbank.org/WBSITE/EXTERNAL/TOPICS/EXTEDUCATION/0,,contentMDK:20521252~menuPK:738179~pagePK:148956~piPK:216618~theSitePK:282386,00.html>
- Tonmanee, N., & Kuneepong, P. (2004). Impact of land use change in bangkok metropolitan and suburban areas. *Delta Series 4*, , 114. Retrieved from <http://www.metropolitandeltas.org/downloads/Impact%20of%20land%20use%20change%20in%20Bangkok.pdf>
- Tuovinen, J. E., & Sweller, J. (1999). A comparison of cognitive load associated with discovery learning and worked examples. *Journal of Educational Psychology*, *91*(2), 334-341.
- U.S. Department of State. (2010). *Thailand*. Retrieved 11/23, 2010, from <http://www.state.gov/r/pa/ei/bgn/2814.htm>
- Warr, P. G. (1993). *The Thai economy in transition*. Cambridge England; New York, NY, USA: Cambridge University Press.
- Yongsiri, S. (2011). *Personal interview*. Hydroponic Expert.

Appendix A: Semi-structured Interview Questions and Responses for Designing and Constructing the Aeroponic Garden

Appendix A.1: Interview with Ajarn Pataraporn, administrator and our main contact/liaison for the Wat Pathumwanaram School

Ajarn Pataraporn Jirojvongse

January 13th, 2011 12:00pm

Present:

Professor Paul Davis

Professor Jennifer deWinter

Professor Richard Vaz

Jon Anderson

Katelyn Comeau

Nicole D'Angelo

Jason Parker

Pipat Poovatanasedj

Valash Sirikate

Onpapat Wongratsameetham

Questions and Responses:

1. What do you understand to be the purpose of this project?

To design and construct an aeroponic garden and to assist the agriculture teacher in her agriculture classroom to help students understand soil-less agriculture.

2. Why would you like us to focus specifically on aeroponics?

Aeroponics is not used at Wat Pathumwanaram School but we would like to have this technology to demonstrate here. Aeroponic plants grow faster and use less water than most types of soil-less agriculture. The school wishes to promote this technology both inside and outside of the school to the surrounding community. We are looking to expand the soil-less techniques used here.

3. What is the school's connection to soil-less agriculture technologies?

The Wat Pathumwanaram School is a demonstration school. Other schools come to this school to learn from the existing hydroponics garden.

4. Who is the audience for the aeroponic garden, who will be seeing it and using it?

The students and other people around the school. The students might use the garden in class to learn about aeroponics so it should not be too difficult for the students to use or clean. Others may come to see the garden, so it should be easy to understand so others can see and understand how it works.

5. Which of the two sectors of this project are of highest priority to you and why?

The aeroponic garden is the most important part of this project because it helps this school demonstrate new technologies to other schools and members of the community.

6. What resources are available to our project team when we build the garden?

There are not many materials that you all will be able to use that we have. The rooftop where the new garden is going to be built has some old soil-less systems that you can use if you would like.

7. Does the Wat Pathumwanaram School believe the budget to begin building the garden will be available?

We want the garden to be built at the school, and it seems that the garden will be a good investment. We want the garden to be long-lasting and a good investment for the school. The school is on a limited budget because the money was not put aside in the budget before. We will submit a budget request, but are not sure if we will be able to get all of the required funding for the garden to be built.

Appendix A.2: Interview with Ajarn Suntaree Gervais, hydroponic expert

Ajarn Suntaree Gervais

January 19th, 2011 9:00am

Present:

Katelyn Comeau

Nicole D'Angelo

Questions and Responses:

1. Which steps in hydroponics do you feel are most important to teach students?

The most important steps to teach students are seeding, transfer, harvest, and general care of plants. Also, mixing nutrient solution is important as well.

2. Are there problems with hydroponic systems that occur frequently?

Yes, hydroponic systems are subject to pest infestation and if are not maintained can result in growth of fungus and plant disease. The amount of sunlight, nutrient solution, and the temperature are all important factors to consider when monitoring a hydroponic system.

3. How do you manage insects in a hydroponic garden?

I use a small amount of detergent mixed with water and I spray the leaves of the plant with this mixture to deter insect infestation. Using netting will also significantly reduce the amount of insects that can infect the garden. The underside of the plants in the garden must be inspected for bugs because the insects can ruin the whole harvest.

4. Can you suggest ways to combat extreme heat?

Using netting to block out some of the sunlight may help but if the netting is too thick it will block out too much of the sun and the plants will not properly grow. Spraying the plants occasionally with water can cool the temperature.

5. How often do you recommend a hydroponic garden be cleaned?

Hydroponic systems need to be cleaned after every harvest. This will also help prevent pests and will make sure the system is clean before a new harvest.

6. Can you suggest any specific methods for cleaning this type of garden?

To clean a hydroponic garden, you need to drain the nutrient solution and rinse the system with water. A mixture of bleach or detergent with water in very low concentrations should be used to scrub the garden and then should be thoroughly rinsed with water. The garden should then be allowed to dry in the sunlight before using again. It is also important to keep the area around a hydroponic garden clean.

Appendix A.3: Interview with Ajarn Songyot Yongsiri (Ajarn Tun), hydroponic expert

Ajarn Songyot Yongsiri (Ajarn Tun)

February 2nd, 2011 11:15am

Present:

Jon Anderson

Katelyn Comeau

Nicole D'Angelo

Jason Parker

Pipat Poovatanasedj

Valash Sirikate

Onpapat Wongratsameetham

Questions and Responses:

1. Have you ever worked with aeroponic gardens? Can you elaborate?

I do not work with aeroponic gardens but I have experienced them in Chiang Mai, a city in northern Thailand. There are commercial aeroponic farms there but these seem to work well because this region of Thailand is more temperate. Aeroponics is difficult in Thailand because of the warm climate.

2. Which of the aeroponic garden designs do you think would be most appropriate for Wat Pathumwanaram School?

The A-frame design is generally the most simple to operate and maintain and provides adequate space for roots to grow in. This would probably be the easiest for you to construct as well. This A-frame can be made from wood. It will be a cheaper material and easier material to work with and build. The reservoir or base of the garden can be made from wood too.

3. Can you suggest steps that should be taken to maintain a working aeroponic garden?

Maintaining the general cleanliness of any soil-less garden is important. Aeroponics specifically requires water filters in the pump because the nutrient solution can clog the nozzles. These filters should be cleaned every week. Sunlight and temperature are

important factors in aeroponic farming. The A-frame design will trap a lot of heat so insulating or cooling the nutrient solution is important. A fan may be able to cool the internal temperature but the nutrient solution will quickly evaporate and light will get into the system. I recommend using high-quality foam to insulate the system and the nutrient reservoir should be elevated of the ground to avoid the transfer of heat from the ground. An aluminum frame may also become corroded over time due to the nutrient solution minerals. Wood is a better material to use for this reason as well. If the wood is sealed and water-proofed it will last a long time.

Appendix A.4: Interview with Professor at KMITL, Dr. Itthisuntorn Nuntagij, aeroponic expert

Dr. Itthisuntorn Nuntagij

January 19th 10:00am

Present:

Jon Anderson

Jason Parker

Pipat Poovatanesedj

Valash Sirikate

Onpapat Wongratsameetham

Questions and Responses:

1. What type of aeroponic garden do you use?

An A-frame design made of steel frame and Styrofoam. The base is made from molded plastic that was custom designed.

2. What type of design do you think would be best suited for a school in Bangkok such as the Wat Pathumwanaram School?

The A-frame design is probably best because it is the most simple to build and maintain. The plumbing is also a lot simpler. The size of it can also be adjusted to fit your size restrictions.

3. Can you estimate the cost of this garden design?

Yes, 13,000-20,000 THB.

4. Where did you get the materials to build this garden?

Some of the materials were provided by the school for free. The sprayers were purchased at Super Products. The timer was custom made and the pump is available at home improvement stores.

5. What are limitations that we should consider when designing an aeroponic garden?

The A-frame design traps heat during the summer which could potentially harm the plants. The temperature should ideally stay below 30 degrees Celsius. The pump must also be pressurized to supply all of the plant roots with nutrient solution. You should use

a 100 micron filter on the output side of the pump to eliminate particles that could clog the nozzles.

6. Can you suggest anything to address the high internal temperature of an A-frame aeroponic garden?

To cool the internal air temperature, you could use two fans to circulate ambient air into the garden. This would cool the air temperature inside the system.

7. What would be an appropriate base for an A-frame garden that was built on a rooftop?

A fish tank would be appropriate for your needs. It is relatively inexpensive and readily available in Bangkok. There are various sizes as well that could be used to fit the parameters of the roof.

8. What kind of foam should be used for an aeroponic system?

High density foam that is 1 inch in thickness is ideal for aeroponics.

9. What other materials are necessary for construction?

PVC can be used for the plumbing and is both cheap and readily available. A pH probe and an EC meter are good tools to monitor the nutrient solution but the pH probe is expensive. Both are recommended.

10. Is the nutrient solution used in aeroponics any different than the solution used in hydroponics?

No, they can both be used.

11. Can you suggest any plants that would be appropriate for an aeroponic garden in Bangkok?

Chinese kale and morning glory are both plants that can survive in the temperatures in Bangkok.

Appendix B: Semi-structured Interview Questions and Responses for Developing Educational Material

Appendix B.1: Joint interview with Ajarn Pataraporn, administrator and our main contact/liaison for the Wat Pathumwanaram School, and Ajarn Lalita, current agriculture teacher at WPS

Ajarn Pataraporn Jirojvongse and Ajarn Lalita Prasart

January 12th, 2011 10:00am

Present:

Jon Anderson

Katelyn Comeau

Nicole D'Angelo

Jason Parker

Pipat Poovatanasedj

Valash Sirikate

Onpapat Wongratsameetham

Questions and Responses:

1. What do students typically have trouble with when learning about hydroponics?

Students are not interested in the class. They are not involved and seem bored sometimes. They do not understand why hydroponics is important.

2. What are your ideas and goals for any newly developed material?

Like we said before, the students do not understand why hydroponics is important. Some of the students understand the steps, but they do not understand why they are important. We really want them to understand why it is important. We are looking for the students to understand why hydroponics is important and why the steps are important. We want the students to understand soil-less agriculture too. Not just hydroponics, but why soil-less agriculture is important.

3. What are some of the other goals that you have of the students in the agriculture class?

The students should understand soil-less agriculture and should be able to compare and contrast the techniques. They should have the knowledge to know which of these techniques is better for growing plants.

Appendix B.2: Interview with Ajarn Lalita, current agriculture teacher at WPS

Ajarn Lalita Prasart

February 2nd, 2011 1:30pm

Present:

Onpapat Wongratsameetham

Jon Anderson

Questions and Responses:

1. What are your educational goals for your agriculture courses?

To give the students a better understanding of types of agriculture and to teach them to be able to use the hydroponic system. I want the students to understand more about hydroponics and why it is important and I want them to be more interested in the class. I want the students to understand the benefits of soil-less agriculture.

2. What age levels should any developed material be appropriate for?

Students in seventh, eighth, and ninth grade will be learning about agriculture. There are also two levels of students. The required class is general and does not involve as much detail as the free elective class. The free elective class has students who chose to study agriculture in hydroponics for their free class. The students know more about agriculture and hydroponics.

3. What educational activities do you prefer to use?

I sometimes bring the students to the roof to work in the garden. I sometimes teach while we are on the roof, and sometimes they clean the garden.

4. Can you give an example of a successful teaching experience you had?

One successful teaching experience: Nutrient solution demonstration. This seemed to work. The students paid attention and seemed to have fun and were engaged.

5. What things do you find to be challenges in the classroom?

Students have a hard time paying attention in class. I like when students pay attention.

6. Do you find the roof-top garden to be a useful educational tool?

In some instances, the rooftop garden is a useful tool but students will lose focus easily and if it is too hot out the students do not like being on the roof. Also, sometimes the garden is not ready for the students so it cannot be used. During a typical roof-top demonstration, about

10-15 of the students are not interested in the material and become inattentive or wander away from the rest of the group.

7. What type of media do you typically use in your classes?

I typically use PowerPoint presentations and hydroponic equipment as media in my classroom. I use PowerPoint the most.

8. What types of soil-less agriculture do you teach in your class?

I teach briefly about all three types of soil-less agriculture (hydroponics, aeroponics, and substrate culture) in my class, but I go into detail only about hydroponics because that is the system that the school currently has.

9. Are there materials that you currently use that we could assist you in further developing?

My PowerPoint slides could be updated or changed.

10. What is the primary method that you use to present information to your students?

PowerPoint lectures.

11. Do you use handouts with your lectures?

No, students simply take notes. I used to use handouts but the students just threw them away.

12. Is there specific material in your classes that students seem to have trouble understanding?

Yes, the students often struggle with understanding the pH and electrical conductivity of the nutrient solutions and the process of preparing the nutrient solution. They also have trouble remembering the names of plants, the names of equipment used, and the time required for steps of farming, such as harvesting.

13. Do all three grade level students have difficulty with the same material?

No, the seventh grade students may also lack summarizing skills so must be told what to write down when taking notes.

14. What do you use to assess or test the students?

I use written exams when I test the students.

Appendix B.3: Interview with Ajarn Monlada Sukalarm, former biology teacher at WPS

Ajarn Monlada Sukalarm

February 3rd 2011, 10:00am

Present:

Pipat Poovatanasedj

Questions and Responses:

1. Are you familiar with the general teaching styles used at the Wat Pathumwanaram School?

Yes, I completed my teacher training at the Wat Pathumwanaram School.

2. Can you give any thoughts on what types of teaching are used here and what methods might be appropriate to introduce?

The types of teaching that I have seen used are lectures, experiments, and field work. The most popular of these is the use of lectures for multiple reasons. Teachers are often most comfortable using lectures and because of difficulties with funding, they are often teaching large classes with upwards of 40 students.

3. Do you think that teachers at the Wat Pathumwanaram School would be comfortable using other methods of teaching?

I believe that some would be willing to adapt their teaching style but only if this does not drastically changing the way they teach. Recent reforms in the Thai education system have attempted to introduce new teaching methods into schools, but have sometimes been ineffective because teachers are not properly trained or are not comfortable changing the way that they teach.

Appendix C: Organization Charts for All Gathered Information

Appendix C.1: Gathered Information for the Design and Build of the Aeroponic Garden at WPS

Source of Information Key	
PL:	Project Liaison: Ajarn Pattaraporn, Administrator at WPS
BR:	Background Research on Aeroponics
RE:	Rooftop Evaluation at WPS
AT:	Ajarn Tun, Hydroponic Expert in Thailand
ASG:	Ajarn Sunturee Gervais, Hydroponic Expert from Hawaii, has practiced hydroponics in Thailand as well
DN:	Dr. Itthisuntorn Nuntagij, Professor at KMITL

Aeroponic Garden at the Wat Pathumwanaram School						
				Hydroponic Experts		Aeroponic Experts
<u>Source of Information:</u>	PL	BR	RE	AT	ASG	DN
Design Criteria:						
A-frame design may be the easiest to build						X
Nutrient solution reservoir off ground				X		
Wood frame or PVC frame over aluminum				X		
Must be area for the roots to grow inside				X		
Garden must be kept clean					X	
Garden must be durable/long lasting	X					
Garden must have a construction manual	X					
Garden should be aesthetically pleasing	X					
Model garden for WPS and community	X					
Must have water filter		X		X		X
Must be a closed system		X		X		X
Must have a reliable power source		X	X	X		
High required maintenance		X		X		X
Requires constant water source		X	X			
High initial cost		X				X
Requires pressurized pump and spray nozzles		X		X		X
Hot in Thailand, way to control temperature			X	X		X
Needs adequate hours of sunlight daily			X	X	X	
Must adequately fit space on rooftop	X		X			
Timing circuit strongly recommended				X		X
Need insect and weather protective netting	X		X		X	
Should insulate base of garden				X		X
Garden must produce vegetables (appropriate for Thai climate)	X				X	X
Highly recommend pump for nutrient solution reservoir				X		X
Hanging sprayers may be more effective for A-frame				X		X
Able to be operated and maintained by students	X				X	
Garden must have a maintenance plan	X				X	
Garden should/can function all year-round	X	X				
Garden should be cost effective	X					

Appendix C.2: Gathered Information for the Developed Educational Material at WPS

Source of Information Key	
PL:	Project Liaison: Ajarn Pattaraporn, Administrator at WPS
BR:	Background Research on Education
AA:	Ajarn Aom, Agriculture Teacher at WPS
AM:	Ajarn Monlada Sukalarm, Former Biology Teacher at WPS

Educational Material to Complement the Agricultural Curriculum at WPS				
	<u>Source of Information:</u>			
<u>Educational Criteria:</u>	PL	BR	AA	AM
The material must involve the teacher			X	X
The material should make use of demonstrations/experiments		X		
Preparing nutrient solution is an important topic to cover			X	
EC and pH values are hard for students to understand and remember (activity for this)			X	
Visual for the information of the plants that are grown in hydroponic garden			X	
The material should cover details about hydroponics	X		X	
The material should cover the general steps of hydroponics			X	
The material should compliment lecture/powerpoints			X	X
The material should increase student attention		X	X	
The material should be visually appealing		X	X	
The material should adhere to both the agriculture students & free elective students			X	
It should not introduce radical changes to the teacher's curriculum		X		X
The material should compliment the content of the classroom		X		
Should involve the rooftop as a resource			X	
Should incorporate teamwork		X		
It should not introduce radical changes to the teacher's teaching methods		X	X	
Collaborative/Group Learning		X		
Able to use hydroponics outside of the classroom	X	X		
The material should achieve determined educational goals		X	X	
Material should show the benefits of soil-less agriculture	X		X	

Appendix D: Aeroponic Garden Construction Manual

Aeroponic Garden: Construction Manual

Wat Pathumwanaram School

Created by students from Chulalongkorn University and Worcester Polytechnic Institute



This manual provides the necessary information for constructing an aeroponic garden that is the same as the model at the Wat Pathumwanaram School in Bangkok, Thailand. The manual provides a complete list of components including the cost and source of each. It also provides detailed drawings and instructions for constructing the specific subsystems of the aeroponic garden.

The generous support of the Siam Kempinski Hotel, the Wat Pathumwanaram School, and Mr. Songyot Yongsiri made the construction of this aeroponic garden possible.

Table of Contents



Required materials and tools list	3
Garden frame and reservoir parts	4
Pump and sprayer system parts	5
Miscellaneous parts	8
Specialty tools	9
Illustrated construction guide	10
Constructing the frame and reservoir	10
Installing insulation foam and lining	12
Installing pump system	17
Installing sprayer system	21
Finishing touches	25
Ideas on expanding the system	27
Appendix A: Frame and reservoir drawings	28

Required materials and tools lists





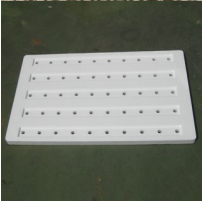

All of the required materials and special tools for the construction of the aeroponic garden are organized into tables by subsystem. Each component is listed with a picture, description, source, required quantity, and cost. Each part is also listed with a part number that has been assigned for easy reference throughout this document.

Many parts for the garden at the Wat Pathumwanaram School were generously donated from various sources (cost denoted by N/A). In the case that all parts must be purchased by the builder the estimated cost of this garden is: **฿ 23,000.**

Garden frame and reservoir parts

Part	Description and Part #	Source	Qty	Cost (฿)
	Aeroponic garden frame – wood PN: FAB-001	Manufactured and donated by external source. (Eng. drawings in Appendix A)	1	N/A
	Hydroponic foam boards PN: HYD-001	Donated by Mr. Songyot Yongsiri	6	N/A
	Insulation foam (80cm x 120cm x 25cm) PN: FOAM-001	Donated by Mr. Songyot Yongsiri	14	N/A
	Plastic garden lining PN: FAB-002	Donated by Mr. Songyot Yongsiri	1	N/A

Pump and sprayer system parts

Part	Description and Part #	Source	Qty	Cost (₱)
	Automatic water pump - At least 150 watts - Ex: Mitsubishi WP205Q3 PN: PUMP-001	Home Pro	1	₱ 6090
	1" PVC pipe - Available in 4m lengths PN: PVC-001	Home Pro	1	₱ 115
	½" PVC pipe - Available in 4m lengths PN: PVC-002	Home Pro	1	₱ 49
	1" PVC inlet PN: PVC-003	Irrigation Technology Company, Ltd.	1	₱ 111
	1" PVC check valve PN: PVC-004	Irrigation Technology Company, Ltd.	1	₱ 196
	1" PVC to 1" NPT adapter (male) PN: PVC-005	Home Pro	7	₱ 49







	1" PVC to 1" NPT adapter (female) PN: PVC-006	Home Pro	2	₱ 16
	1" filter (120 Micron) - disc type filter PN: PVC-007	Irrigation Technology Company, Ltd.	1	₱ 166
	1" PVC ball valve PN: PVC-008	Home Pro	1	₱ 85
	1" PVC elbow fitting PN: PVC-009	Home Pro	7	₱ 70
	1" to 1/2" PVC reducer PN: PVC-010	Home Pro	1	₱ 7
	1/2" PVC Coupler PN: PVC-012	Home Pro	1	₱ 49

	1" solenoid valve - Match voltage to timer PN: PVC-013	Irrigation Technology Company, Ltd.	1	₪ 935
	20 mm PE hose PN: SPY-001	Home Pro	1	₪ 330
	1/2" PVC pipe clips PN: SPY-002	Home Pro	6	₪ 24
	20 mm PE end clamp PN: SPY-003	Home Pro	1	₪ 40
	Netafim single sprayer - with check valve PN: SPY-004	Irrigation Technology Company, Ltd.	4	₪ 152
	Netafim sprayer assembly PN: SPY-005	Irrigation Technology Company, Ltd.	9	₪ 918

Miscellaneous parts

Part	Description and Part #	Source	Qty	Cost (฿)
	Timing system - Match voltage to solenoid valve PN: TIME-001	To be determined	1	฿ 5000

Specialty tools

Part	Description and Part #	Source	Qty	Cost (฿)
	PVC glue PN: TLS-001	Home Pro	1	฿ 95
	PVC/PE cutting tool PN: TLS-002	Irrigation Technology Company, Ltd.	1	฿ 140
	PE punch tool PN: TLS-003	Home Pro	1	฿ 105
	Styrofoam glue PN: TLS-004	Donated by Mr. Songyot Yongsiri	1	N/A
	PVC Teflon tape PN: TLS-005	Home Pro	2	฿ 38
	Silicone sealant tube PN: TLS-006	Home Pro	4	฿ 712

Construction guide

Each subsection is broken down with complete illustrated assembly instructions where appropriate. For components that should be manufactured by an external source detailed engineering drawings and descriptions of the components are provided.

Constructing the frame and reservoir

The frame and reservoir should be constructed out of wood by following the engineering design drawings in Appendix A. The drawings provide complete detail for size information leaving some manufacturing details at the discretion of the builder.

In order to save time and ensure high quality, a construction company was contracted to manufacture the frame and reservoir for the garden at WPS. The company used the engineering drawings that are provided in Appendix A.

To easily install the insulation foam and lining it may be appropriate to make the frame detachable from the reservoir.

After the structural components of the frame and reservoir are complete, several other steps must be complete before moving to the pump and spraying systems.



A water-resistant outdoor paint should be applied thoroughly to the wood frame and reservoir. The paint should be applied in 2-3 separate coats to provide complete coverage. The paint selected for the aeroponic garden at WPS is:

4 Seasons High Gloss Enamel oil-based paint – white



Installing the insulation foam and lining

Next the insulation foam should be installed into the reservoir by following these steps:

- 1) Cut the foam boards from standard 1” foam boards (FOAM-001) to completely insulate the interior of the reservoir. Specific sizes of each foam piece will depend on the fabrication of the reservoir and should be cut to fit.

Description	Qty.
Side foam insulation – small	2
Side foam insulation – large	2
End foam insulation	2
Bottom foam insulation	3
Triangle foam board	2
Base form insulation	3

Cut the foam using a straight edge and razor blade.



- 2) Install all interior foam insulation pieces (all above except triangle foam board and base foam insulation) into the reservoir and attach using foam glue (TLS-004).



- 3) Install both triangle foam pieces onto the frame. They must each be made from two separate pieces of foam (because one is not large enough) and bonded together using foam glue (TLS-004). Attach triangles to the frame using foam glue (TLS-004).



- 4) Test fit the standard hydroponic boards onto the frame. If there are gaps (that will allow light into the system) near the top of the frame, cut and attach foam strips as appropriate with foam glue (TLS-004).



- 5) Seal all joints of the insulation foam using silicone. (TLS-006)



- 6) Install ½” hose clips (SPY-003) using screws along the spine of the frame. Space each clip about 12” from one another.



- 7) Carefully install the plastic garden lining (FAB-002) into the garden so that it is as smooth as possible.



- 8) If the frame has been detached from the reservoir, it is now appropriate to reattach it. Place the hydroponic boards on the frame. Do not glue the hydroponic boards, as they should be removable.

At this point the only source of light entering the garden should be the plant holes in the hydroponic boards. All other holes or cracks should be filled with Styrofoam or silicone.

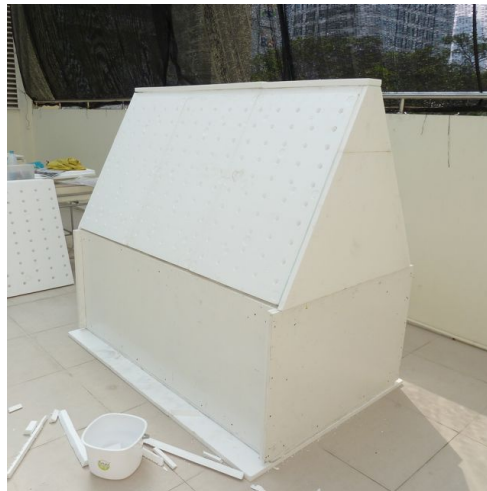

Installing the pump system

Now that the reservoir and frame are complete, it is appropriate to construct the pump system. A system flow diagram is included below to show the order of all major components.

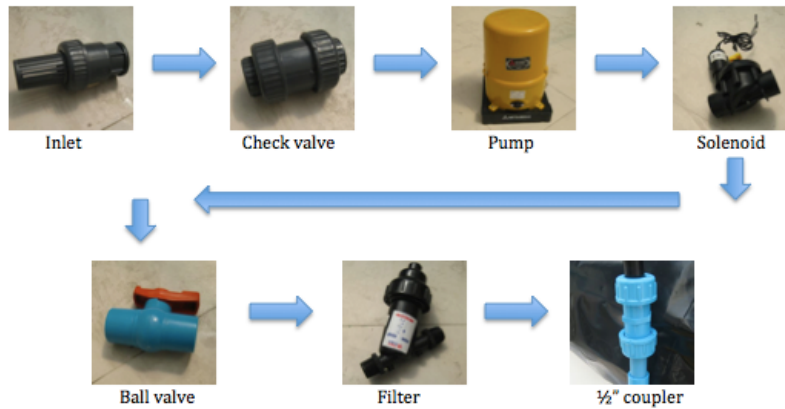

Notes for assembling the pump system:

- All threaded fittings should be installed with Teflon tape (TLS-005) prior to any gluing.
- Do not over-tighten any of the threaded PVC fittings.
- All PVC pipe should be cut and dry fit before anything is glued in order to make sure everything is the correct length.
- When gluing the PVC work quickly because it sets very fast. Use a generous amount of glue for joining the pipes.

- 1) Install the treaded PVC fittings (PVC-005 & PVC-006) to the appropriate components as illustrated in the pictures below. Make sure to use an ample amount Teflon tape (TLS-005) on each threaded fitting and do not over-tighten.



PVC-005



PVC-003



PVC-005



PVC-004



PVC-005



PVC-005



PUMP-001



PVC-005



PVC-005



PVC-013



PVC-005

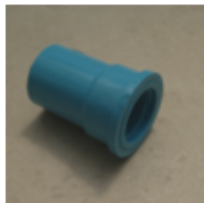

PVC-006



PVC-007



PVC-006

- 2) Assemble the inlet assembly by cutting the 1" PVC pipe (PVC-001) to the appropriate lengths. It is important that the inlet is placed as low as possible in the reservoir. Using a piece of 1" PVC pipe punch a hole into the side of foam triangle for the inlet pipe.



- 3) Assemble the input end of the pump system by following the diagram and cutting the 1" PVC pipe (PVC-001) to the appropriate lengths.



- 4) Assemble the output end of the pump system by following the diagram and cutting the 1" PVC pipe (PVC-001) to the appropriate lengths.



- 5) Now it is appropriate to glue all the joints of the input and output assemblies of the pump system. Allow the glue to dry for 24 hours before using the system.



Installing the sprayer system

Now that the reservoir and pump systems are complete it is appropriate to install the sprayers. The following steps walk through this process.

- 1) Using a piece of ½” PVC pipe (PVC-002) punch holes at both ends of the foam triangles for the 20mm PE hose (SPY-001). The holes should be punched such that the hose can be run through the hose clips, along the spine of the frame. Run 20mm PE hose across the entire spine of the frame.



- 2) On the pump side of the frame cut the 20mm PE hose (SPY-001) to a length that is appropriate to attach to the ½” PVC coupler (PVC-012). On the far end leave a few inches and install a 20mm PE end clamp (SPY-003).



- 3) Install 5 Netafim sprayer assemblies (SPY-005) equally spaced along the length of the 20mm PE hose inside the garden. Use the PE punch tool (TLS-003) to create a hole to push the assembly into.



- 4) Install 4 more Netafim sprayer assemblies (SPY-005) between each of the sprayers installed in step 3. Remove the included hose from these assemblies before attaching them. Use the PE punch tool (TLS-003) to create a hole to push the assembly into.



- 5) Install 4 Netafim single sprayers (SPY-004) to the ends of 20mm PE hose near the entrance and exit from the garden. Use the PE punch tool (TLS-003) to create a hole to push the assembly into.



- 6) Attach the 20mm PE hose to the pump assembly at the ½" PVC coupler and tighten completely.



Finishing touches

Cut one or two maintenance/viewing windows into the end triangle foam pieces of the garden. These are used for checking the EC and pH, sprayers, and roots of the plants without taking the plant boards out. It is important that windows have covers that can be replaced when not being used, to prevent light from entering the system.

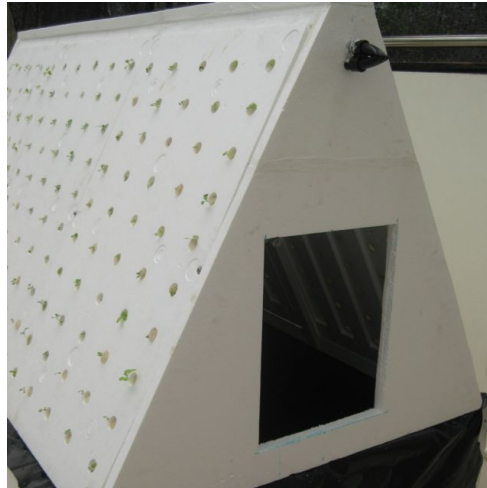

Attach each hydroponic foam board with screws and washers, which can easily be removed, to the frame. This prevents the boards from falling off the garden due to wind or other sources.



Attach the wires from the solenoid valve (PVC-013) to the timing system (TIME-001). Suggested cycle timer is 30 seconds ON and 120 seconds OFF. Experiment with the cycle times to produce the most desirable plant results. The timer pictured is an example of the type of timer needed. The one pictured is on the aeroponic system at King Mongkut's Institute of Technology Ladkrabang.



If no timer is present in the system, the head on the solenoid valve can be turned $\frac{1}{4}$ turn manually to allow flow.

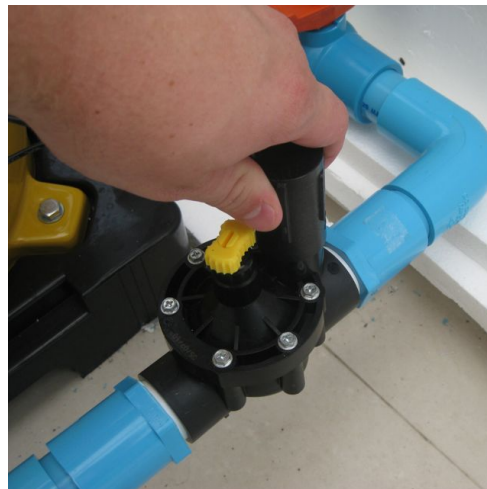

Ideas on expanding the system

The system design allows for easy expansion. The pump being used for the garden can support 1-2 additional gardens if desired. The 20mm PE hose with sprayers on additional gardens should be coupled to the end of the 20mm PE hose on the current garden. An aquarium pump should be placed in each additional garden to pump the nutrient solution back to the reservoir of the primary garden.

Appendix A: Frame and reservoir drawing

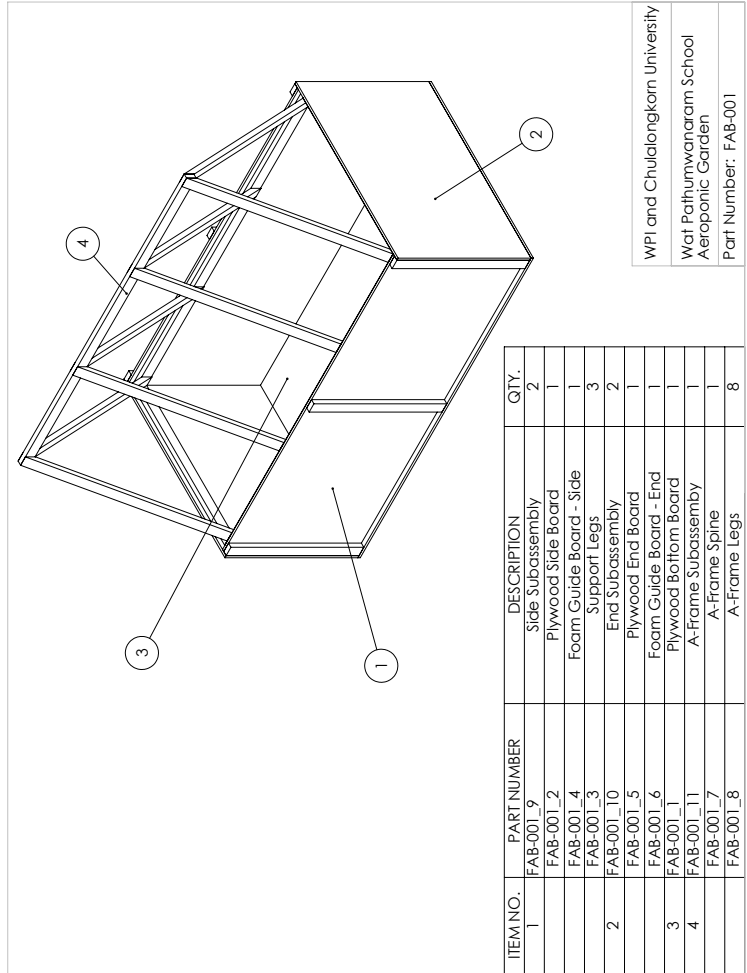

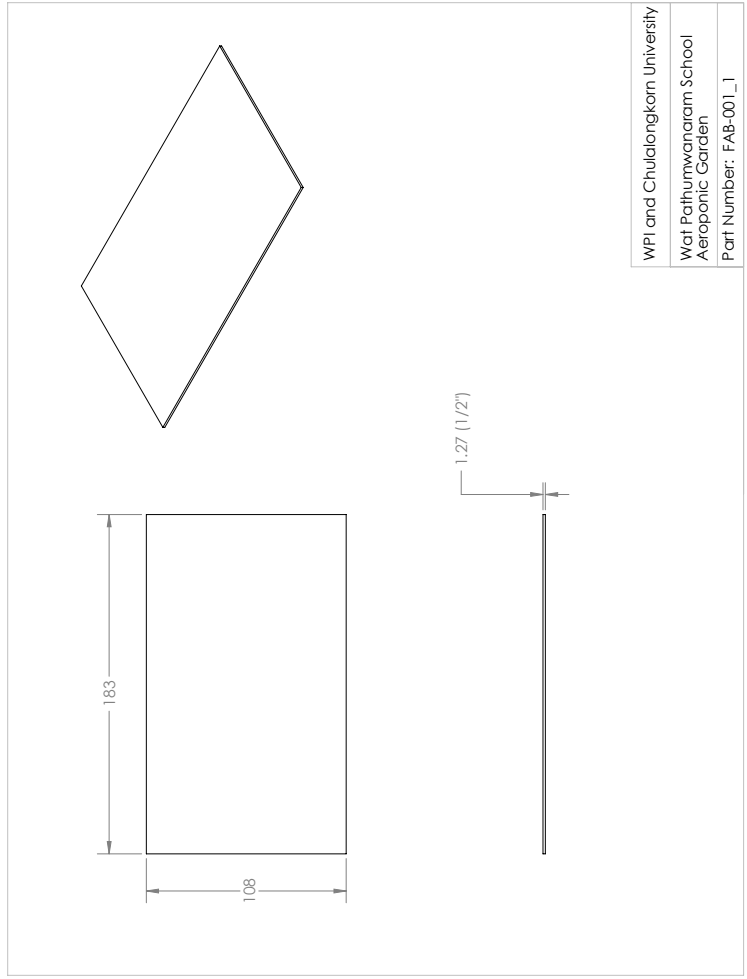

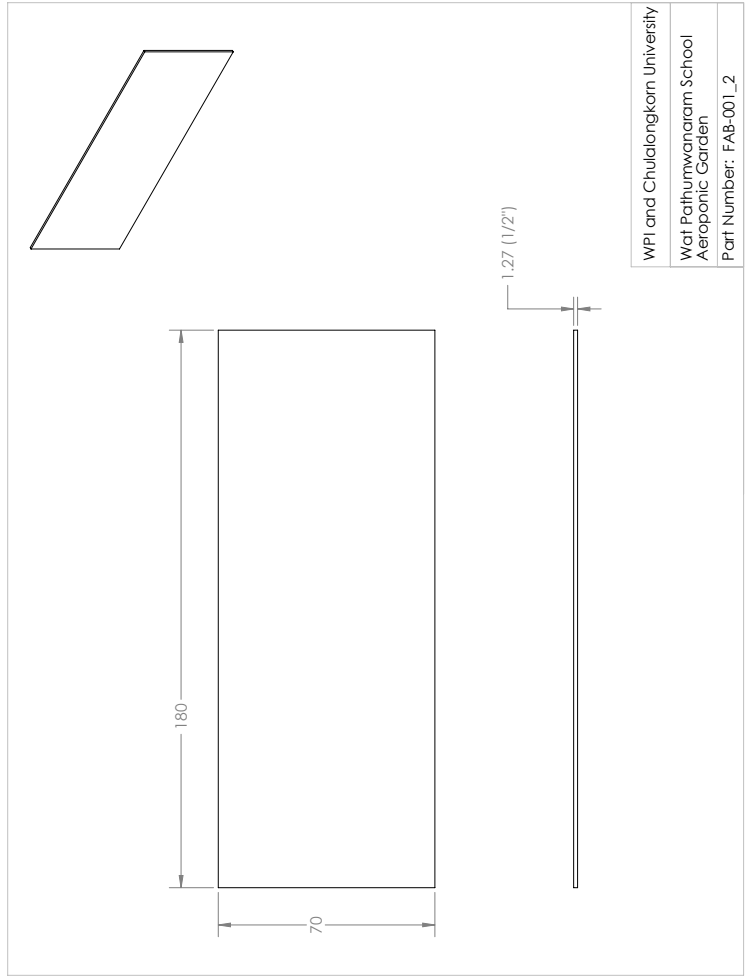

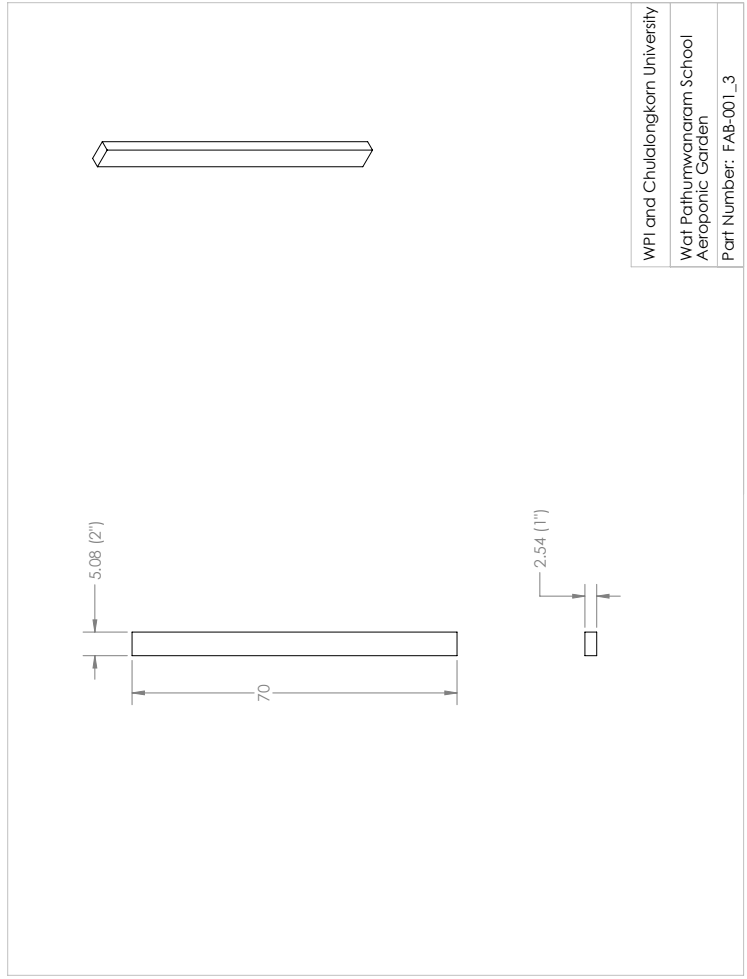

WPI and Chulalongkorn University
Wat Pathumwanaram School
Aerobonic Garden
Part Number: FAB-001_3

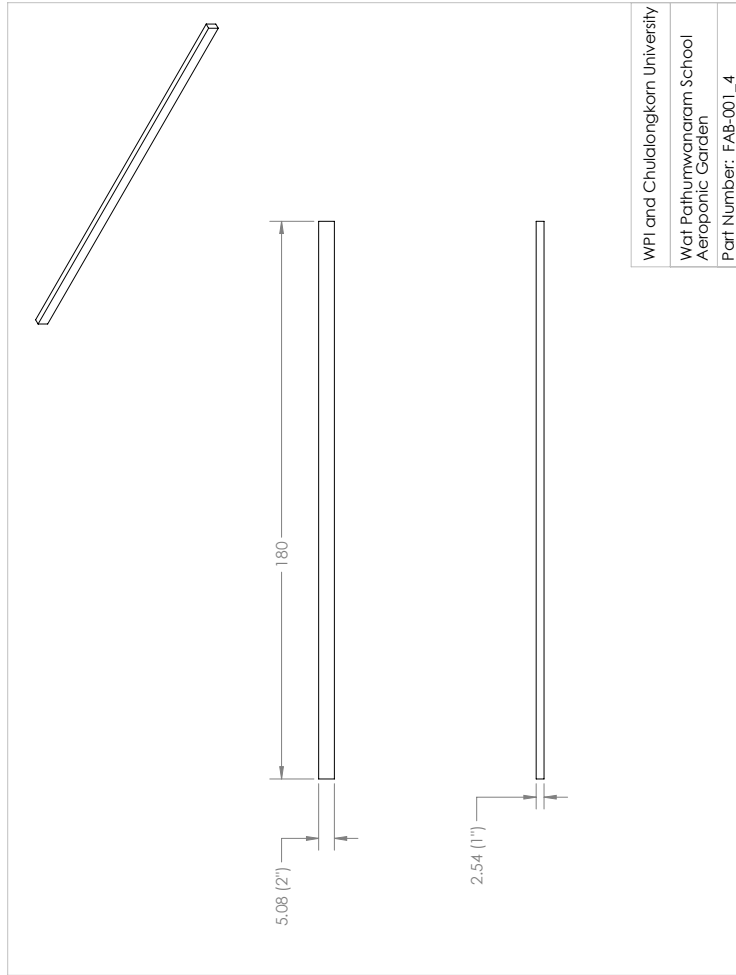

WPI and Chulalongkorn University
Wat Pathumwanaram School
Aerobonic Garden
Part Number: FAB-001_4

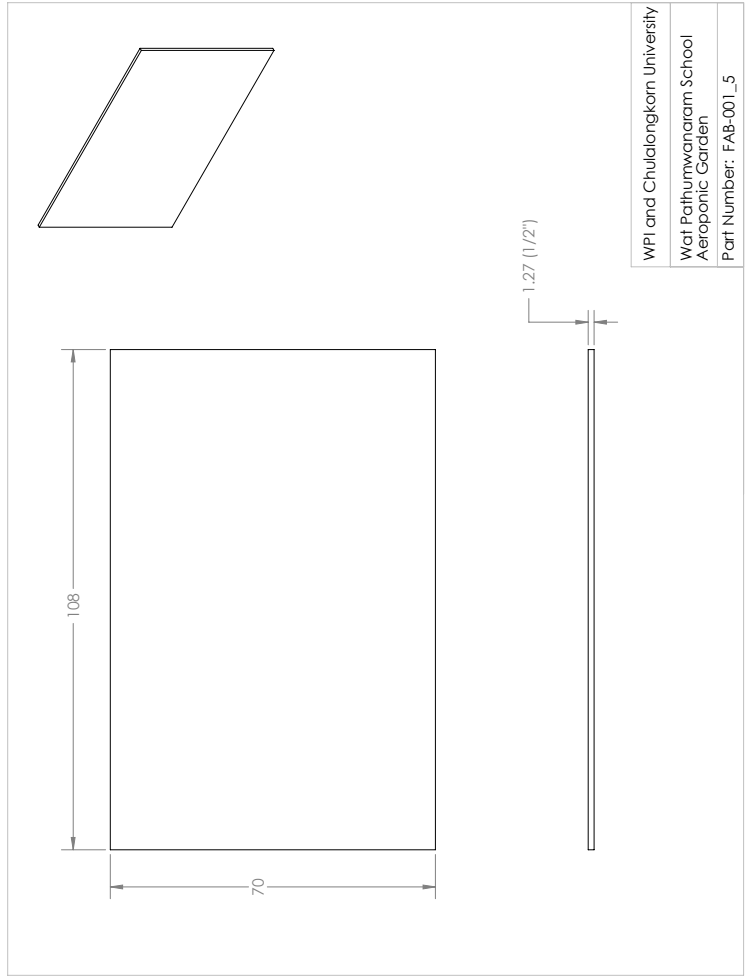

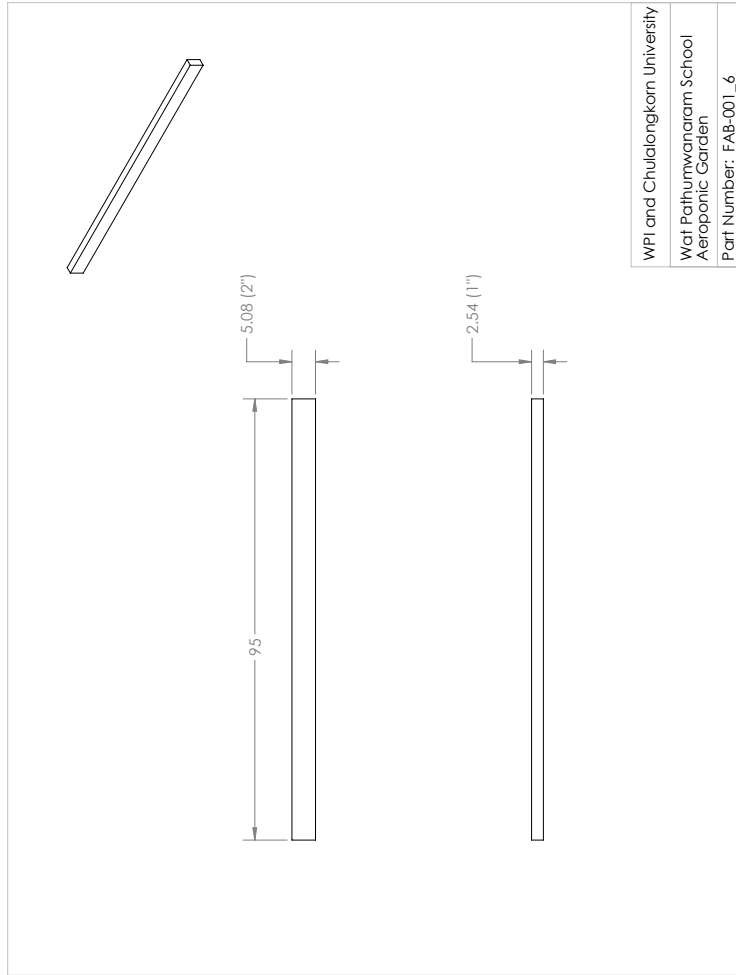

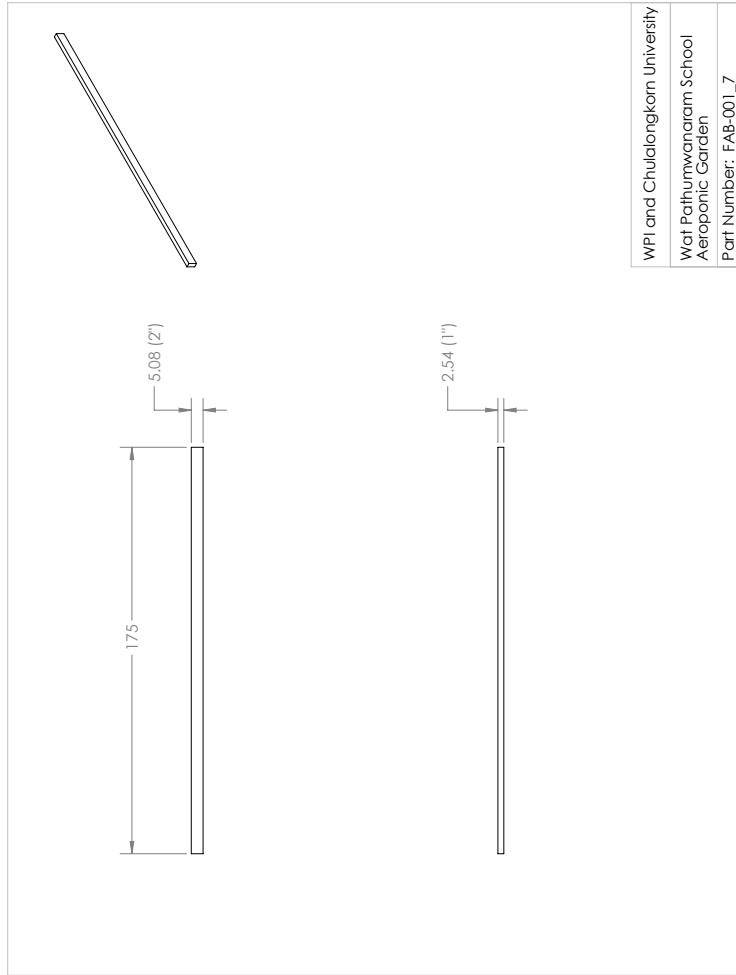

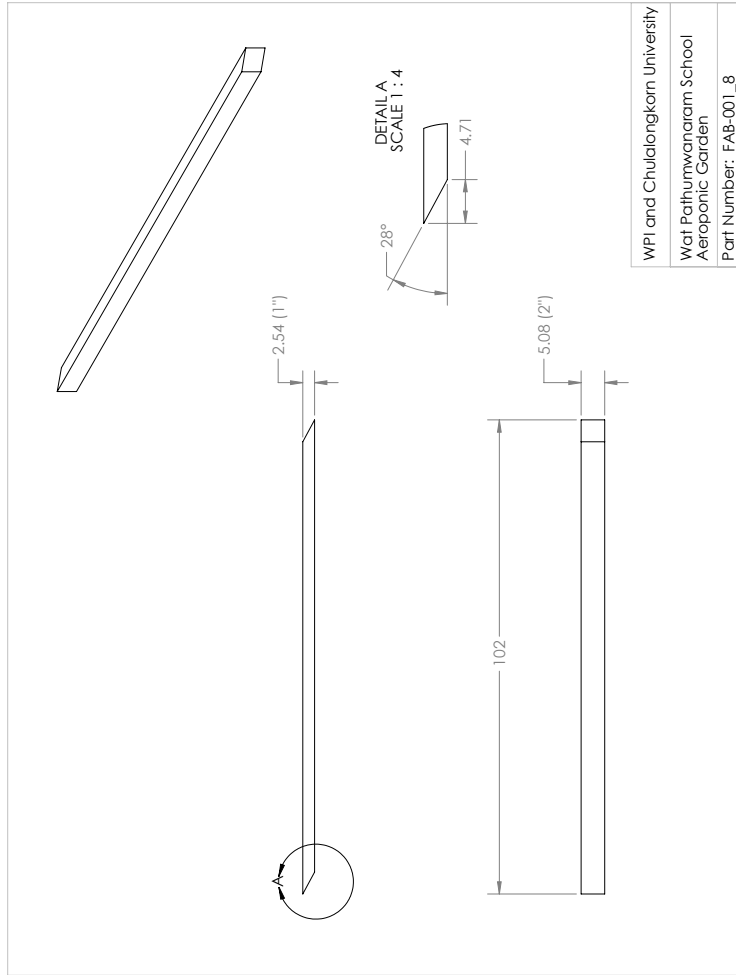

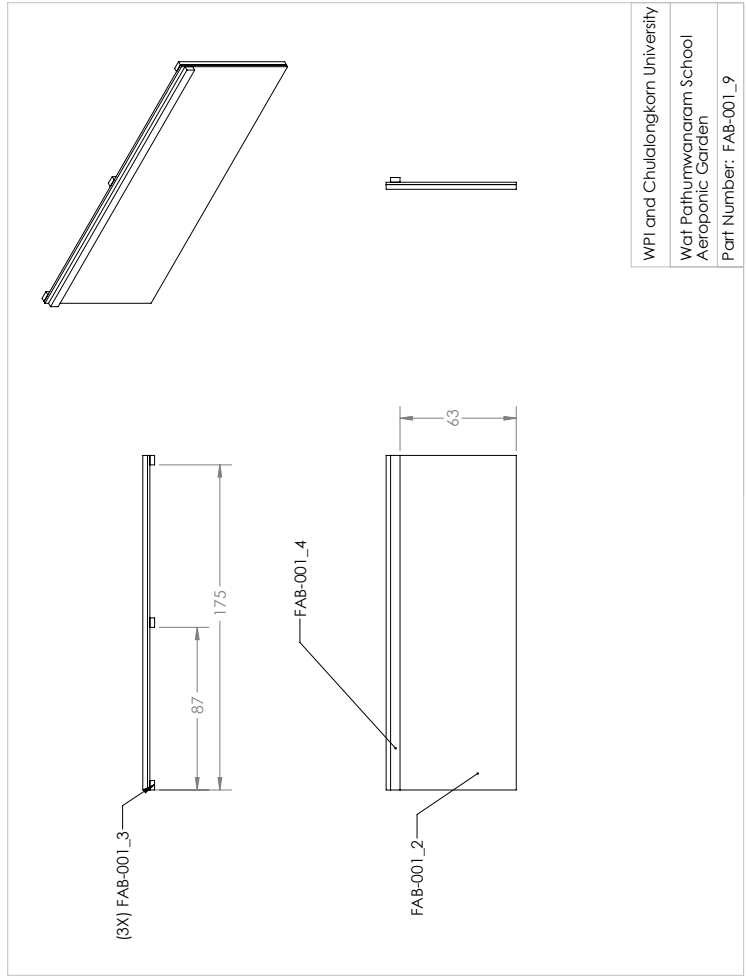

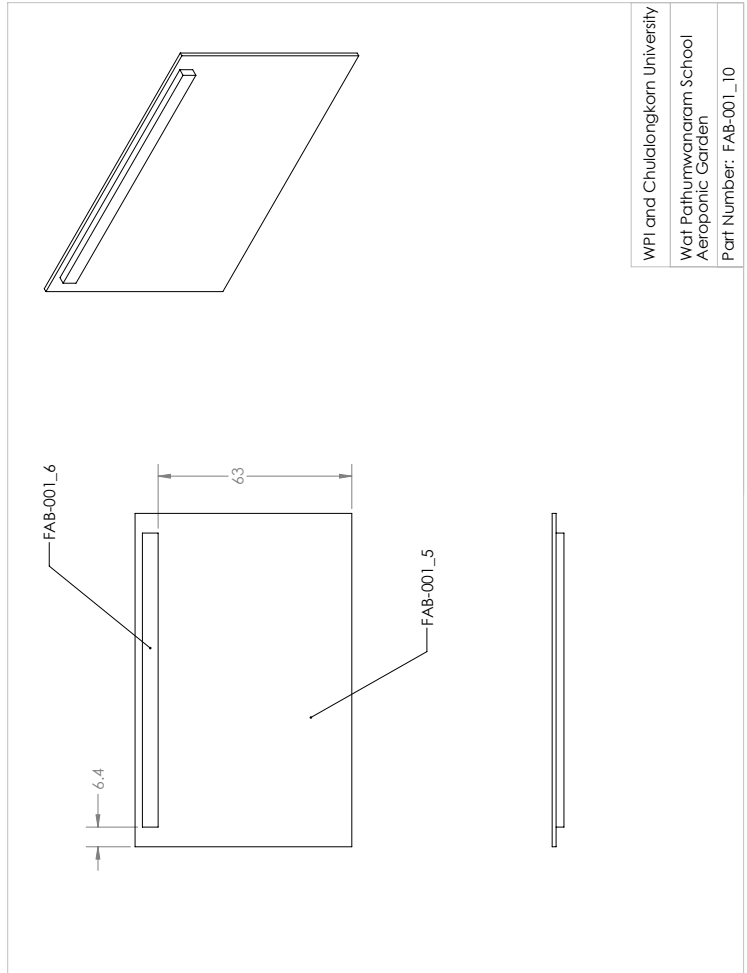

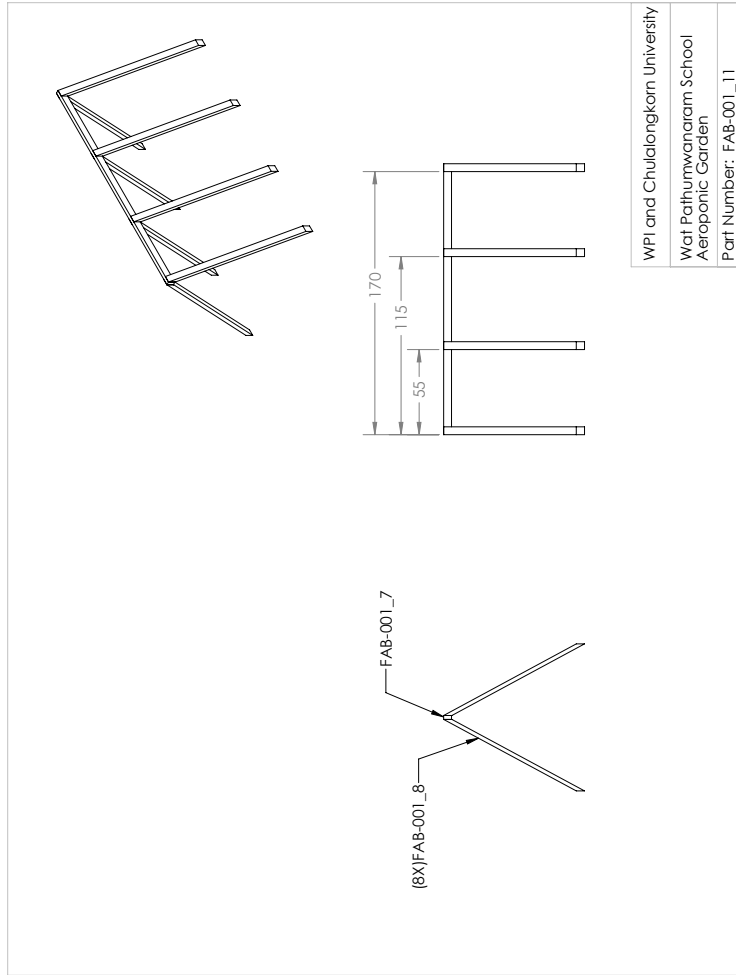

WPI and Chulalongkorn University
 Wat Pathumwanaram School
 Aerobonic Garden
 Part Number: FAB-001_11

Appendix E: Aeroponic Garden Maintenance Manual

Aeroponic Garden: Maintenance and Operation Manual

Wat Pathumwanaram School

Created by students from Chulalongkorn University and Worcester Polytechnic Institute



Contents

Section 1: Start-up Procedure	3
Section 2: Nutrient Solution Initial Mixing.....	4
Section 3: Planting	7
Section 4: Maintenance Schedule	9
Section 5: Nutrient solution maintenance.....	10
Section 6: Nozzle Maintenance	11
Section 7: Filter Maintenance (weekly)	13
Section 8: Filter Maintenance (between plantings).....	14
Section 9: System Flush	16
Appendix A: Calculation of proper mix ratio for nutrient solution	18
Appendix B: Pump Factory Manual	19
Appendix C: Daily Checklist.....	25

Section 1: Start-up Procedure



1. Insure outlet valve is in the closed position and pump is unplugged.



2. Make sure the motor output shaft is free-spinning by turning the screw on the back of the shaft with a screwdriver.

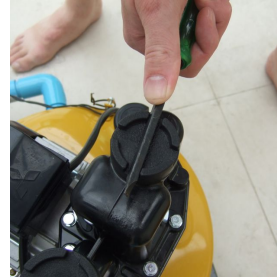

3. Remove pressure tank fill cap. Use a screwdriver to loosen. Make sure pump is not pressurized before opening. Fill tank with clean water and replace cap.



4. Fill reservoir with approximately 30 cm of clean water.



5. Plug pump in, open outlet valve and let pump run for several minutes to ensure all air is purged from system.

Section 2: Nutrient Solution Initial Mixing



1. Mix the stock A chemicals with 8.7 liters of water.



2. Thoroughly mix the solution ensuring chemicals are fully dissolved.



3. Mix the stock B chemicals with 8.4 liters of water.

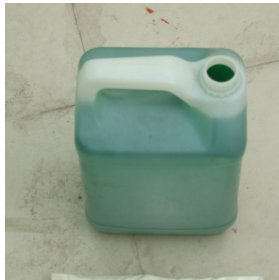

4. Thoroughly mix the solution ensuring chemicals are fully dissolved.

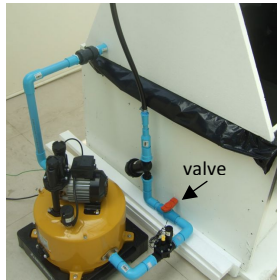

5. Insure outlet valve is in the closed position and pump is unplugged.



6. Measure the height of the nutrient solution. Use this measurement to calculate the required amount of stock A and stock B, refer to appendix A for calculation.



7. Pour in the required amount of stock A into the reservoir.

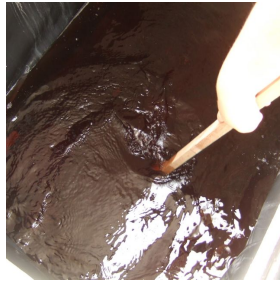

8. Thoroughly mix the stock A/water solution.



9. Pour in the required amount of stock B into the reservoir.

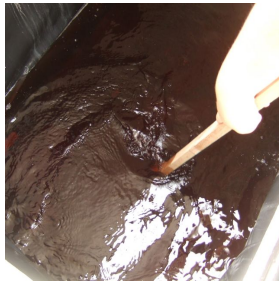

10. Thoroughly mix the stock A/StockB/water solution.

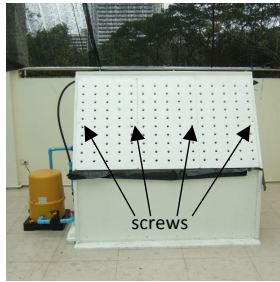

11. Place foam boards on garden and fasten screws to retain.



12. Plug pump in, open outlet valve and let pump run for at least an hour to completely circulate and mix nutrient solution.

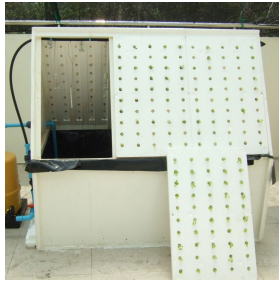

13. Close outlet valve and remove one of the foam boards to gain access to nutrient solution.



14. Insert end of EC meter into nutrient solution and read EC level.



15. If EC value is high add water, circulate for an hour and remeasure. Repeat as necessary. If EC value is low add equal parts stock A and stock B, circulate for an hour and remeasure. Repeat as necessary. Refer to Appendix A for calculations.

Section 3: Planting



1. Slice foam into 3 cm cubes.

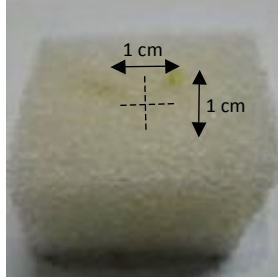

2. Cut 1 cm long slits in a cross pattern into the center of each cube. Ensure cuts go through to the bottom of the foam cube in order to allow roots to penetrate.

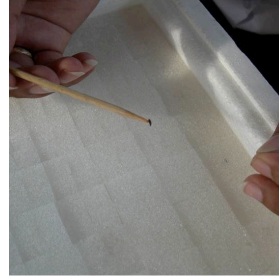

3. Insert seeds into the intersection of the two slits

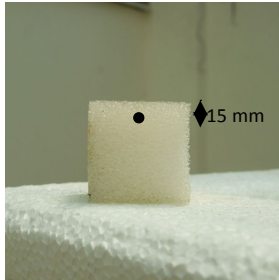

4. Push seed just below the surface of the foam to a depth of 10 to 15 mm.



5. Pour water onto foam until moist. Water twice a day.

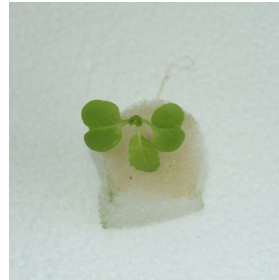

6. In 7 to 10 days when the roots have penetrated the bottom of the foam cube and the first set of leaves has sprouted, the seedlings are ready to be transplanted into the garden.



7. Insert leaves through back of foam board.



8. Press foam into hole ensuring roots protrude foam board.



9. Plants should look like this after transplant step.

Section 4: Maintenance Schedule

Daily

1. Check nozzles for correct operation. Refer to Section 6: Nozzle Maintenance.
2. Check electrical conductivity (EC) of nutrient solution. Refer to Section 5: Nutrient Solution Maintenance.
3. Check nutrient solution level. Refer to Section 5: Nutrient Solution Maintenance.

Weekly

1. Partially disassemble and clean filter. Refer to Section 7: Filter Maintenance (weekly).

Between Plantings

1. Fully disassemble and clean filter. Refer to section 8: Filter Maintenance (between plantings).
2. Flush pump system with clean water. Refer to Section 9: System Flush.
3. Flush nozzles with clean water. Refer to Section 9: System Flush.
4. Clean reservoir, frame, and foam with clean water. Refer to Section 9: System Flush.

Section 5: Nutrient solution maintenance



1. Insure outlet valve is in the closed position and pump is unplugged.

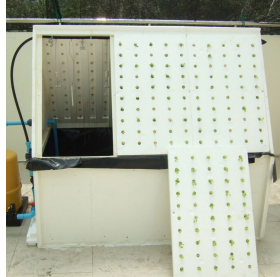

2. Remove one of the foam boards to gain access to nutrient solution.



3. Insert end of EC meter into nutrient solution and read EC level.



4. If EC value is high add water, circulate for an hour and remeasure. Repeat as necessary. If EC value is low add equal parts stock A and stock B, circulate for an hour and remeasure. Repeat as necessary. Refer to Appendix A for calculations.



5. Insure there is at least 20 cm of nutrient solution. If not fill reservoir with water to a level of 30 cm. Add the appropriate amount of Stock A and Stock B, depending on how much water was added. Refer to Appendix A for calculations. Repeat steps 3 and 4.

Section 6: Nozzle Maintenance



1. Correct nozzle spray pattern.



2. If nozzle is clogged, turn off outlet valve and unplug pump.

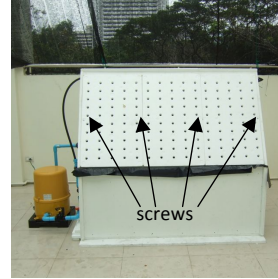

3. Remove foam by first removing screws then pulling foam boards straight out.

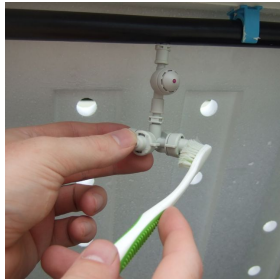

4. Try removing debris from nozzle with a brush.



5. If nozzle is still clogged, remove nozzle from pressure sensitive valve. Hold valve with one hand and pull nozzle down while twisting in order to remove.

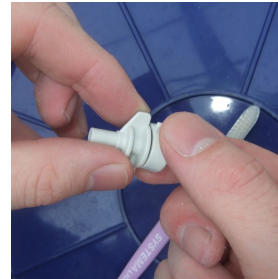

6. Unlock nozzle cap by twisting counterclockwise.



7. Remove nozzle cap.



8. Clean nozzle cap with brush.



9. Remove jet from nozzle.



10. Clean jet with a brush, if needed a pin can be used to clear clog.

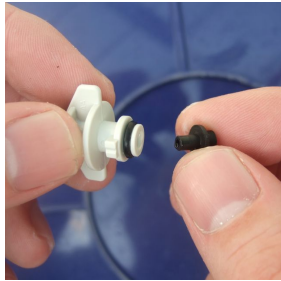

11. Replace jet.

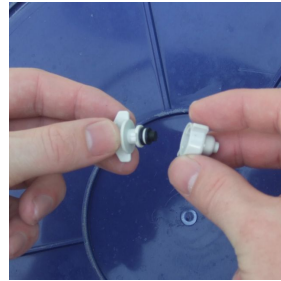

12. Replace nozzle cap and turn clockwise to lock.



13. Replace nozzle assembly by pressing nozzle assembly into pressure sensitive valve.

Section 7: Filter Maintenance (weekly)



1. Turn off outlet valve and unplug pump.



2. Remove cap by twisting counterclockwise and unscrewing.



3. Pull out filter.



4. Separate disks by pulling ends outward



5. Rinse disks under water and clear build up from between them.



6. Close filter by pressing ends together.



7. Insert filter spring side first into filter housing.



8. Screw on cap and hand tighten.

Section 8: Filter Maintenance (between plantings)



1. Remove cap by twisting counterclockwise and unscrewing.



2. Remove cap by twisting counterclockwise and unscrewing.



3. Pull out filter.

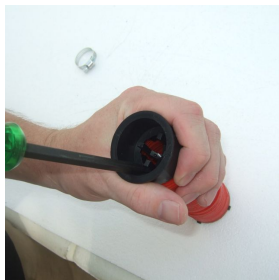

4. Remove filter cap by compressing tang with a screwdriver and pulling up on cap. Use caution to avoid breaking tang.



5. Remove disks.

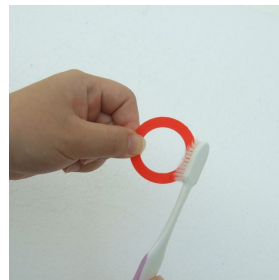

6. Clean disks with a brush and water.



7. Replace disks and filter cap.



8. Close filter by pressing ends together.



9. Insert filter spring side first into filter housing.



10. Screw on cap and hand tighten.

Section 9: System Flush



1. Turn off outlet valve and unplug pump.

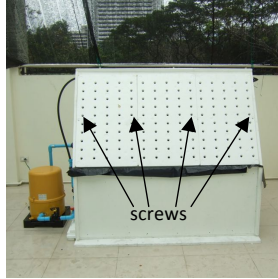

2. Remove foam by first removing screws then pulling foam boards straight out.



3. Unplug pump, close outlet valve, then unhook outlet hose by loosening coupling and pulling hose out.



4. Insert one end of a drain hose into coupling and tighten. Place the other end into drain.



5. Plug pump in, open outlet valve, and empty nutrient solution into drain until nutrient solution is level with top of pump inlet, close outlet valve, and unplug pump.

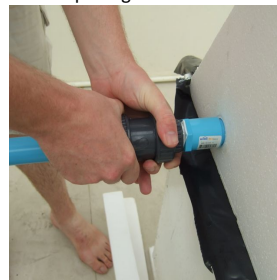

6. Unscrew and remove check valve coupling.

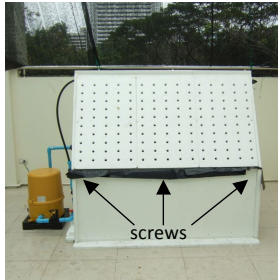

7. Remove the six screws holding the top to the base.



8. Lift top up, slide forward, and place pump inlet into a full bucket of clean water.



9. Reposition pump and reconnect check valve. Plug pump in, open outlet valve, and run pump for at least 20 minutes to flush old nutrient solution from system. Insure bucket remains full of clean water.



10. Unplug pump, close outlet valve, remove drainhose, and replace outlet hose. Turn pump on for approximately 10 minutes in order to flush nozzles. Insure bucket remains full of clean water.

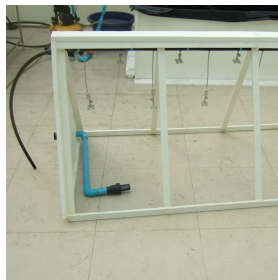

11. Remove outlet hose, check valve coupling, lift top off and place on floor. Tip reservoir over in order to drain remaining nutrient solution from reservoir. Clean reservoir, top, and foam with clean water.



12. Replace top, replace screws in top, reconnect outlet hose, and reconnect check valve coupling. Follow nutrient solution mixture and planting procedures.

Appendix A: Calculation of proper mix ratio for nutrient solution

Volume of stock A (V_A) and stock B (V_B) in cubic centimeters required can be calculated as follows,

$$V_A = V_B = q * V$$

Where q is the amount of stock recommended in table1 and V is the volume of water in the reservoir calculated as follows,

$$V = 15.8 * h$$

Where h = height of water in reservoir measured in centimeters.

Table 1 Required amount of Stock A and Stock B

Plants	Stock A / 1 liter water (q)	Stock B /1 liter water (q)	Concentration (EC)
Lettuce	3 cc	3 cc	1.50-1.80
Kale	10 cc	10 cc	4.70-5.00
Thai Plants	5 cc	5 cc	2.20-2.60

In order to adjust the EC of the nutrient solution, use 1 cubic centimeter of stock A and stock B for an increase of 0.03.

Appendix B: Pump Factory Manual
Mitsubishi pump manual (W9-205Q3)

1. Warning (could cause serious injury or fatal consequences if ignored)

<p>1. Installation 1.1 Do not install the pump where power cord can be wet or humid. Must be installed on stable, strong floor. The outlet wire must be 2.5 square millimeters by size and not being shared. 1.2 Do not place the power cord inside that pump cover. 1.3 The power outlet must be grounded with the provided ground rod standardized by specialist. (Must never connect the ground rod with gas tube, water pipe, lightning rod or telephone landline, it might cause electrocute.</p>	<p>2. Maintenance and repair 2.1 Do not modify and change part(s) of pump from factory defaults. 2.2 The electricity to pump must be shut down before maintenance or repair that must be conducted with specialist only.</p> <p>3. Operation 3.1 Do not use pump to flow other liquid than water (e.g. Chemicals, fuel, etc.)</p>
<p>4. Parts 4.1 Do not contact with pump if part(s) of pump are missing (e.g. Missing of pump cover) 4.2 Do not operate the pump while leakage.</p>	

2. Warning (could cause injury or properties damage if ignored)

<p>1. If not operated for a period of time, Should disconnect with electricity</p>	<p>2. Installation Should install the pump away from sunlight exposure or with heat ventilation. If installing on sunlight, avoid using objects to cover the pump (e.g. Plastic bags, fabric), they tend to block heat ventilation.</p>
<p>3. Power wire Should inspect the condition of power wire (electricity) regularly and discontinue using if inspected to be malfunctioned.</p>	<p>4. If unexpected incidents occur, Should disconnect system from electricity immediately, contact Mitsubishi electric customer service.</p>
<p>5. Operate without water Should never operate the pump without water in the system. This will cause serious heat accumulation within the system and damage the part(s) of pump.</p>	<p>6. Avoid contact with pump Should never contact the pump or motor, high temperature is resulted from heat accumulation of the system operation. Should never touch the motor where rotation of part(s) is located.</p>

3. Installation procedures

Example diagrams of pump installation are varied and are shown below.

Diagram 1. Source of water is tanked underground

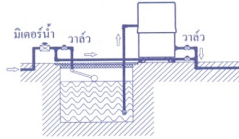

Diagram 2. Source of water is tanked above ground level

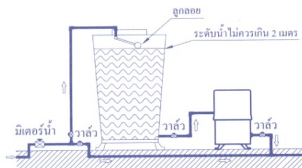

Diagram 3. Source of water that is pond (should be installed as near to pond as possible)

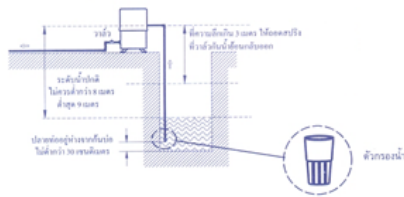
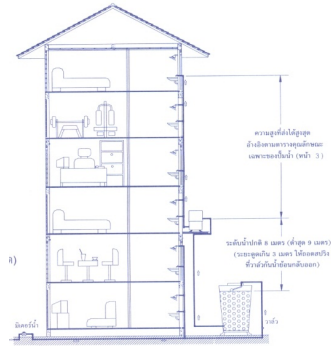

Diagram 4. Installed in high buildings



Notices:

1. During installation, should use the indicated pipe size and be installed nearest to the building avoiding the drop of flow rate.
2. In case of contamination of water source, strainer should be applied at the pipe terminal.
3. The strainer should be installed at least 30 centimeters above ground level preventing the contamination or sand to clog the strainer.
4. Should be installed where it is easily accessible for maintenance, cool and dry preventing rust.
5. Should never modify the pressure switch from factory default, this could cause system damage.
6. In case that the water course is at least 3 meters below the pump, the spring at water valve should be removed preventing the reverse of water flow.
7. In case of applying junctions, corners or bending of pipes, least amount is preferred as preventing the drop of flow rate.
8. If the pump system is directly connected to other devices (e.g. the water boiler, warmer), the suitable pressure and amount of water must be considered.

4. Procedures before operation

1. Use the screw driver release the screw core at the end of motor, allowing the motor core to freely rotatable.
2. Open the tank lid and fill the tank with water. (please see figure)
3. Close the lid.
4. Connect the power cord and the system will begin to draw water in 2-3 minutes.

Notices: If no water flowing from tube, turn off the system and repeat step 1-4.

Pre-operation test

1. Once release the faucet, leave the water to flow for minutes until the motor will start automatically. On the other hand, once lock the faucet; the motor will take 5-10 seconds to full stop.
2. Once the faucet is stopped but the pump is not yet stopped eventually, this indicates leakage in the system. Determine the cause and repair.
3. Once the pre-operation test is completed, dry the system before closing the pump cover.

5. Specification of pump

Model		WP-205Q3		
Motor	Type		CAPACITOR MOTOR	
	Electricity Hz	Hz	50	
	Voltage	Volt	220	
	Motor power	Watt	200	
	Burn resistant		Yes	
Pump	Drawing depth	Meter	9 meters	
	Pushing height	Meter	16	
	Amount (at 12 m.)	Liter/minute	38	
	Amount (highest)	Liter/minute	46	
	Pressure switch	Kg/cm ² (bar)	Close	2.8 (2.74)
			Open	2.1 (2.06)
Tube size	Millimeter (inch)		25 (1")	
External size	Millimeter	W x L x H	425 x 425 x 578	
Net weight including package	Kilograms		21	
Net weight	Kilograms		19	

6. Cleaning and maintenance



1. Disconnect the system from electricity before cleaning and maintenance.

2. Should check on all equipment after use, (at least once a year is recommended)



2.1 Power cord and outlet (including wires) should be checked

2.2 Check for noises and shakes

2.3 Check for leakages

2.4 Check for odor and smokes.

2.5 Check for ground rod.

If suspicious, stop the operation and notify Mitsubishi Electric customer service.

7. Repair

If suspicious, stop the operation and notify Mitsubishi Electric customer service or check the situation with the following table.

Description	Cause	Repair
Release the faucet but water is not flowing (motor is not working and causing no noise)	Power cord could be misplaced	Correct the power cord
	Wire is damaged	Contact the wire provider
	No water in system and causing the system over heat, the burn-resistant system initiated	Check the water source with sufficient water supplied, wait for motor cool down.
Release the faucet but the water is not flowing (Motor is not working but causing noise)	Dregs is causing water flowing fan or other contamination	Use the screw driver rotate the motor core (end-terminal)
Release the faucet but the water is not flowing (motor is working)	Insufficient water supplied or check valve is clogged	Clean the check valve and supply sufficient water
	The drawing tube is clogged	Unclog
The pump is working but water flow is disrupted	The air is drawn during operation at the drawing tube	Seal the leakage
Pump is still working even the faucet is shut	The check valve is contaminated	Remove the check valve lid and clean
	Leakage at pump or tube	Seal the leakage
Pump is working and stopping eventually	The air in pressure tank is insufficient	Release the water in the pressure tank and restart the system

8. Parts of pump

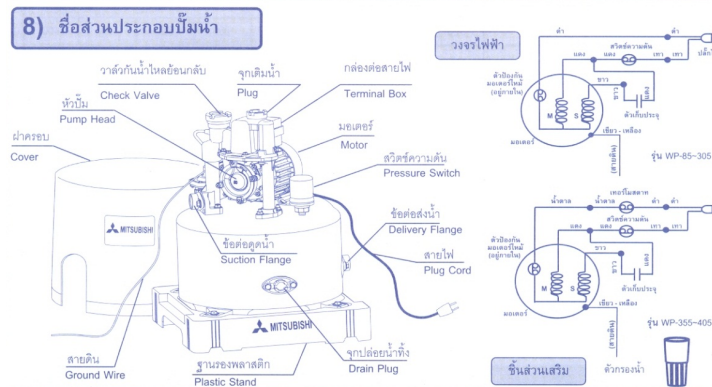

Notices: Burn-resistant system (within the motor) will be initiated in case of motor over heated and terminated when it is cooled down.

Appendix C: Daily Checklist

Date														
Check nozzles														
EC														
Solution level														
Clean filter														
Date														
Check nozzles														
EC														
Solution level														
Clean filter														
Date														
Check nozzles														
EC														
Solution level														
Clean filter														
Date														
Check nozzles														
EC														
Solution level														
Clean filter														

Appendix F: Current Agricultural Curriculum at the Wat Pathumwanaram School

Appendix F.1: Current General Agriculture Class Curriculum

The Wat Pathumwanaram School

Course Syllabus: General Agriculture Class

Topics Covered in Current Agricultural Curriculum at WPS

Provided by: Ajarn Lalita Prasart

Translated to English by: Onpapat Wongratsameetham

Subject: Agriculture

Teacher name: Ms. Lalita Prasart (Ajarn Aom)

Type of subject: General Class

Topics Covered:

- 1. The meaning of hydroponics**
- 2. Advantages of hydroponics**
- 3. Disadvantages of hydroponics**
- 4. Soil-less Agricultural Systems**
 - a. The Aeroponic Technique
 - b. Substrate Culture
 - i. Nutrient solution feeding techniques
 - Over flow
 - Dripping
 - c. Liquid Culture
 - i. Non-circulating system
 - Do not add in air
 - Add in air
 - ii. Circulating system
 - How the system works
 - The Nutrient Film Technique

5. Steps to growing plants in a hydroponic system

- a. Seeding in sponge
- b. Taking care during the seeding step
 - i. Put the seeded sponge into a tray of water
 - ii. Cover the tray with a cloth
 - iii. Water in the morning and in the afternoon
 - iv. It will take about 2-3 days for the plant to grow
- c. 1st transfer
 - i. When the plant grows to about 80%, transfer to the hydroponic table
 - ii. Water the plant in the morning and in the afternoon for about 4 days
 - iii. After 4 days, there will be a strong plant that is ready for the next step
- d. 2nd transfer (to hydroponic table)
- e. Add nutrient solution according to the need of each type of plant, and make sure to take care of both the water and the electrical system until harvest
- f. Do not add any nutrient solution 4-5 days before harvest

6. Plants used in hydroponic gardens at WPS

7. Material used in hydroponics

- a. Sponge for seeding
- b. Seed tray
- c. Grow board
- d. Grow tray
- e. Grow basket
- f. Nutrient solution A&B
- g. Jug for measuring nutrient solution
- h. Pipe
- i. Extended flexible pipe
- j. Pump
- k. Nutrient reservoir
- l. Flip lock
- m. Netting to prevent mosquitoes and birds
- n. EC meter

Appendix F.2: Current Free Elective Curriculum

The Wat Pathumwanaram School

Course Syllabus: Free Elective Class

Topics Covered in Current Free Elective Curriculum at WPS

Provided by: Ajarn Lalita Prasart

Translated to English by: Pipat Poovatanasedj

Subject: Hydroponics

Teacher name: Ms. Lalita Prasart (Ajarn Aom)

Type of subject: Free Elective

Level: 7th grade

Hours: 2 hours per week

1. Course description of what students should be able to do:

- a. See value, importance and benefit of using hydroponic systems
- b. To use and maintain the right equipment for the hydroponic system
- c. Able to analyze, plan, work, evaluate, and improve work related soil-less plants
- d. Able to explain work
- e. Have the understanding to analyze skill
- f. Able to plant with the hydroponic system
- g. Being able to analyze a problem, the cause of the problem, and ways to solve the problem using suitable means

2. Study plan

Semester 1	
Week No.	Course details
1	- Introduction to this course - Meaning of soilless culture - Advantages and disadvantages
2	Factors involved with plants developing in hydroponic system - Genetic - Growth control solution
3	Factors involved with plants developing in hydroponic system - Environment
4	- Greenhouse system - Component table
5	Types of hydroponic systems
6	Factors involved with plants developing in hydroponic system
7	- Seed selection methods - Seeding materials
8	Practice seeding methods
9	Taking care of young plant - Instruction and methods
10	Midterm exam for semester 1
11	- Plant transfer preparation methods - Plant transfer
12	Nutrients solution A and B preparation
14	Measurement on EC value
15	Practical activity: training on seeding
16	Practical activity: training on planting

17	Practical activity: training on seeding
18	Practical activity: training on planting
19	Final exam for semester 1
20	2nd attempts of final exam for semester 1

Semester 2	
1	Plantation preparation
2	- Adding nutrient solution A and nutrient solution B - Lower water level in plantation tray
3	- Insect protection and removal - Practical activity: training on planting
4	- Harvesting method - Packing and selling products
5	Practical skills training
6	Practical skills training
7	Practical skills training
8	Practical skills training
9	Midterm exam for semester 2
10	Practical skills training
11	Practical skills training
12	Practical skills training
13	Practical skills training
15	Practical skills training
16	Practical skills training
17	Practical skills training
18	Practical skills training
19	Final exam for semester 2
20	2nd attempts for final exam for semester 2
	End of 2nd semester

3. Methods used to teach class

- a. Lecture
- b. Demonstration
- c. Experiment
- d. Report
- e. Field trip

4. Materials used in class

- a. Vegetables
- b. Real example
- c. Materials and equipment use for farming
- d. Video
- e. Photo of finished project

Appendix G: Developed Educational Material

Appendix G.1: Re-formatted and re-designed PowerPoint slides compared to the current slides used in the agriculture class, and title slides for the four newly developed PowerPoint presentations

PowerPoint presentations developed by: Valash Sirikate and Onpapat Wongratsameetham

Current slide used in “Hydroponics” PowerPoint lecture



Re-designed and re-formatted slide for “Hydroponics” PowerPoint lecture



Current slide used in “Hydroponics” PowerPoint lecture



Re-designed and re-formatted slide for “Hydroponics” PowerPoint lecture

ความหมาย ข้อดี/ข้อเสีย การปลูกพืชไร้ดิน **ปัจจัยที่สำคัญต่างๆ** การเพาะเมล็ด การดูแลและบำรุงรักษา

ปัจจัยที่สำคัญต่างๆ ▶ ด้านพันธุกรรม
ด้านสิ่งแวดล้อม
ด้านการจัดการ
แร่ธาตุ

ปัจจัยด้านพันธุกรรม

A collage of images showing various hydroponic plants. From left to right: a green leafy plant, a red bell pepper, a cluster of red tomatoes, a green leafy plant, and a row of purple-leafed lettuce plants in a hydroponic system.

Appendix G.2: Game board and example questions and answers used in the developed soil-less agricultural “Jeopardy” game

Game developed by: Katelyn Comeau

Translated into Thai for agriculture class by: Valash Sirikate

Game Board (PowerPoint)

การปลูกพืชไม่ใช้ดิน (Soil-less agriculture)

อุปกรณ์	ขั้นตอนของการปลูกพืชไร้ดิน	ระบบของการปลูกพืชไร้ดิน	พืช	ดูแลรักษาพืช
<u>10</u>	<u>10</u>	<u>10</u>	<u>10</u>	<u>10</u>
<u>20</u>	<u>20</u>	<u>20</u>	<u>20</u>	<u>20</u>
<u>30</u>	<u>30</u>	<u>30</u>	<u>30</u>	<u>30</u>
<u>40</u>	<u>40</u>	<u>40</u>	<u>40</u>	<u>40</u>
<u>50</u>	<u>50</u>	<u>50</u>	<u>50</u>	<u>50</u>

Example question slide from “Jeopardy” game

หมวด ขั้นตอนการปลูกของการปลูกพืชไร้ดิน

ขั้นตอนต่อไป จากการเพาะเมล็ด คือขั้นตอนอะไร?



←

ค่าเงิน 40

Example answer slide from “Jeopardy” game

หมวด ขั้นตอนการปลูกของการปลูกพืชไร้ดิน

ขั้นตอนต่อไป จากการเพาะเมล็ด คือขั้นตอน
อะไร?



การย้ายต้นกล้าลงแปลงปลูก 40

Questions Included in Developed Game

Category 1: Equipment Used

1. Beginner Questions:

- a. What is the name of the material that the seed is first placed into?
 - i. Sponge [picture]
- b. What is the name of the tool that keeps water moving in a hydroponic bed?
 - i. The pump [picture]
- c. What material is used to keep out birds and insects?
 - i. Netting [picture]
- d. What is the name of the bucket that holds the nutrient solution?
 - i. Nutrient reservoir [picture]
- e. What is the name of the tool that the sponge is placed in during transplant?
 - i. Grow Basket [picture]

Category 2: Steps of Soil-less Farming

1. Beginner Questions

- a. What is the first step of soil-less farming?

- i. Seeding
- b. What liquid is necessary to begin the seeding?
 - i. Water
- c. After putting the seeds into the sponge, how many times a day must you water them?
 - i. 2 or 3
- d. What step is after seeding?
 - i. Transplant to hydroponic bed
- e. How many days until you can harvest your vegetables?
 - i. 30-45

Category 3: Soil-less Farming Techniques

1. Beginner Questions

- a. Which type of soil-less agriculture sprays the roots of plants with nutrient solution?
 - i. Aeroponics
- b. Which type of soil-less agriculture submerges plant roots in a nutrient solution?
 - i. Hydroponics
- c. Which type of soil-less farming uses substrates such as perlite, vermiculite, and humus
 - i. Substrate-culture
- d. What is one advantage to hydroponics over traditional farming?
 - i. Uses less water
 - ii. Uses less space
 - iii. Can be used in cities
 - iv. If soil is poor, can still be used
- e. What type of hydroponic system is this?
 - i. Deep Root Floaing Technique

Category 4: Plants

1. Beginner Questions

- a. Which of these plants is Butterhead?
 - b. Which of these plants is Red Coral?
 - c. Which of these plants is Cos?
 - d. Which of these plants is Green Oak?
 - e. Which of these plants is Red Oak?
- 2. Advanced Questions (suggested questions that can be substituted for a more advanced game)**
- a. Identify this plant- Butterhead
 - b. Identify this plant- Green Oak
 - c. Identify this plant –Red Oak
 - d. Identify this plant -Cos
 - e. Identify this plant –Red Coral

Category 5: Caring for Plants

1. Beginner Questions

- a. In order to grow, plants need sunlight, water, air, and _____
 - i. Nutrients
- b. Where on the plants do you look for signs of insects?
 - i. Bottom of leaves
- c. How often should you clean your soil-less garden?
 - i. After every harvest
- d. Is it good to clean a garden with strong chemicals?
 - i. No, the chemicals can harm the plants. Wash with mild chemicals
- e. What are the two most common insects found in a hydroponic garden?
 - i. Aphid & Worm

Appendix G.3: Soil-less Agriculture Posters

Created by: Onpapat Wongratsameetham

Translated to English by: Onpapat Wongratsameetham

Soil-less Agriculture Poster

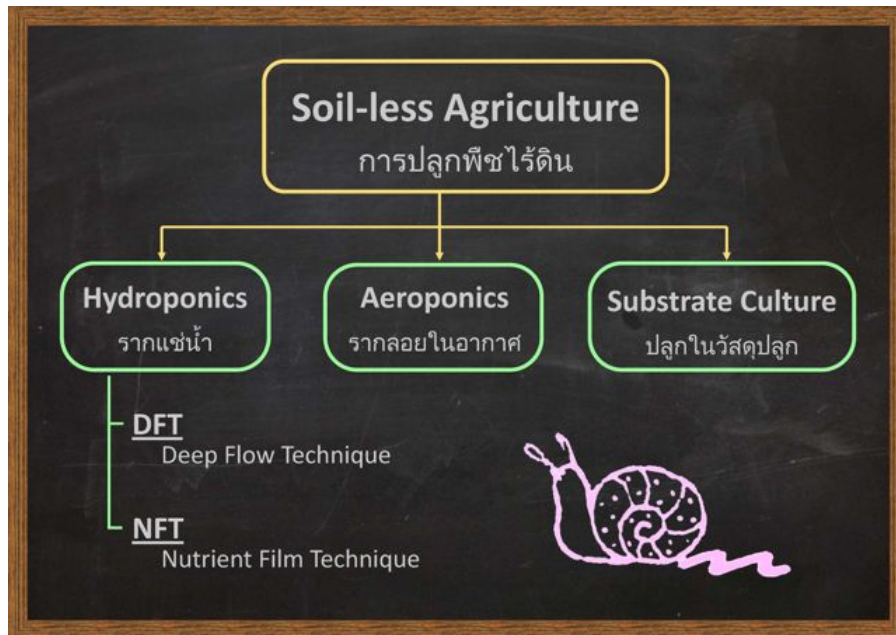

Deep Flow Technique (DFT) Poster

Deep Flow Technique (DFT)

Description:

In the DFT system, plant roots are submerged in a nutrient solution and partially in the air. A pump keeps the nutrient solution moving to prevent growth of algae and to aerate the solution.

Compared to NFT, DFT has deeper nutrient solution. In case of power loss, plant roots remain submerged in the nutrient solution.

The diagram shows a plant with green leaves and brown roots. The roots are submerged in a blue liquid labeled 'Nutrient Solution'. A dashed line indicates the surface of the liquid, and the area above it is labeled 'Air-zone'.

Aeroponics Poster

Aeroponics

Description:
Aeroponics is a type of soil-less farming in which plant roots are suspended in air and sprayed periodically with nutrient solution.

By exposing plant roots to the air, they can receive more oxygen, hydrogen, and carbon in the air.

Since plant roots are sensitive to temperature, plant growth is negatively affected if the air gets too hot.

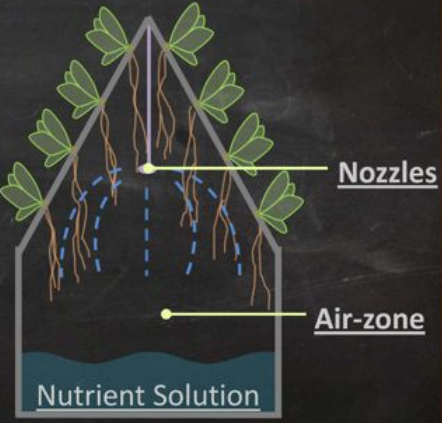

The diagram illustrates an aeroponics system. A plant is shown with its roots suspended in an air zone above a reservoir of nutrient solution. The roots are sprayed with the nutrient solution by nozzles. Labels include: **Nozzles**, **Air-zone**, and **Nutrient Solution**.

Substrate Culture Poster

Substrate Culture



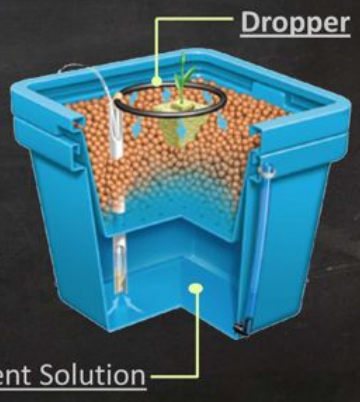

Description:
Substrate culture is a type of soil-less farming that combines hydroponics and traditional farming.

In this system, a medium called a “**substrate**” is used to support plant roots, provide nutrient solution, and supply air. Therefore, it must be able to absorb liquid and allow air to flow.

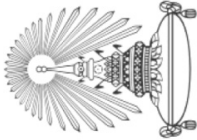

The diagram shows a substrate culture system. A plant is growing in a blue container filled with a substrate. A dropper is used to add nutrient solution to the substrate. Labels include: **Dropper** and **Nutrient Solution**.

Appendix H: Recognition Plaque for the Aeroponic Garden

  <p style="text-align: center;">Siam Kempinski Hotel BANGKOK</p>  	<p>กลุ่มนิสิตจากคณะวิทยาศาสตร์ จุฬาลงกรณ์มหาวิทยาลัย และ Worcester Polytechnic Institute จากประเทศสหรัฐอเมริกา ได้สร้างสวนสาธิต aeroponic ให้แก่โรงเรียนวัดปทุมวนารามฯ เพื่อเป็นประโยชน์ต่อการศึกษาเกี่ยวกับการปลูกพืชไร้ดิน สวนสาธิตนี้มีโอกาสสำเร็จได้หากขาดการสนับสนุนจาก:</p> <ul style="list-style-type: none"> • โรงแรมสยามเดมมิเนสส์ กรุงเทพฯ • โรงเรียนวัดปทุมวนารามฯ • นายทรงยศ ยงศิริ <hr/> <p>Students of Chulalongkorn University and Worcester Polytechnic Institute, USA built this demonstration aeroponic garden for the Wat Pathumwanaram School to use as a model for soil-less agriculture.</p> <p>The construction of the garden would not have been possible without generous support from the Siam Kempinski Hotel, the Wat Pathumwanaram School, and Mr. Songyot Yongsiri.</p>
---	--